

JVC



ENGLISH

ESPAÑOL

FRANÇAIS

CD/SD RECEIVER

KD-AR7500/KD-SHX750

RECEPTOR CON CD/SD

KD-AR7500/KD-SHX750

RECEPTEUR CD/SD

KD-AR7500/KD-SHX750

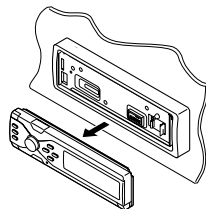

PICT

COMPACT
DIGITAL AUDIO
TEXT

SIRIUS
READY

BBE
DIGITAL



KD-AR7500

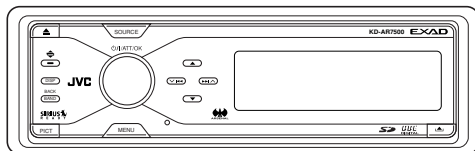

KD-SHX750

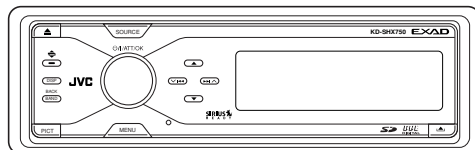

EXAD

For canceling the display demonstration, see page 9.

Para cancelar la demostración en pantalla, consulte la página 9.

Pour annuler la démonstration des affichages, référez-vous à la page 9.

For installation and connections, refer to the separate manual.

Para la instalación y las conexiones, refiérase al manual separado.

Pour l'installation et les raccordements, se référer au manuel séparé.

For customer Use:

Enter below the Model No. and Serial No. which are located on the top or bottom of the cabinet.

Retain this information for future reference.

Model No. _____

Serial No. _____

INSTRUCTIONS

MANUAL DE INSTRUCCIONES
MANUEL D'INSTRUCTIONS

LVT1310-001A

[J]

Thank you for purchasing a JVC product.

Please read all instructions carefully before operation, to ensure your complete understanding and to obtain the best possible performance from the unit.

INFORMATION (For U.S.A.)

This equipment has been tested and found to comply with the limits for a Class B digital device, pursuant to Part 15 of the FCC Rules. These limits are designed to provide reasonable protection against harmful interference in a residential installation. This equipment generates, uses, and can radiate radio frequency energy and, if not installed and used in accordance with the instructions, may cause harmful interference to radio communications. However, there is no guarantee that interference will not occur in a particular installation. If this equipment does cause harmful interference to radio or television reception, which can be determined by turning the equipment off and on, the user is encouraged to try to correct the interference by one or more of the following measures:

- Reorient or relocate the receiving antenna.
- Increase the separation between the equipment and receiver.
- Connect the equipment into an outlet on a circuit different from that to which the receiver is connected.
- Consult the dealer or an experienced radio/TV technician for help.

IMPORTANT FOR LASER PRODUCTS

1. CLASS 1 LASER PRODUCT
2. **CAUTION:** Do not open the top cover. There are no user serviceable parts inside the unit; leave all servicing to qualified service personnel.
3. **CAUTION:** Visible and invisible laser radiation when open and interlock failed or defeated. Avoid direct exposure to beam.

Warning:

If you need to operate the receiver while driving, be sure to look ahead carefully or you may be involved in a traffic accident.

Cautions:

- Do not insert 8 cm (3-3/16") discs (single CDs) into the loading slot. (Such discs cannot be ejected.)
- Do not insert any disc of unusual shape—like a heart or flower; otherwise, it will cause a malfunction.
- Do not expose discs to direct sunlight or any heat source or place them in a place subject to high temperature and humidity. Do not leave them in a car.

How to reset your unit

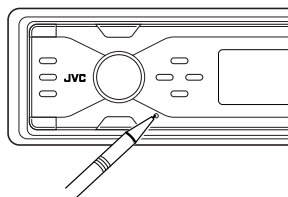

This will reset the microcomputer. Your preset adjustments will also be erased.

Notice:

The display window built in this receiver has been produced with high precision, but it may have some ineffective dots. This is inevitable and is not malfunction.

How to reset your unit	2
How to read this manual	4
How to forcibly eject a disc	4
How to change the display pattern	5
How to enter the various menus	5

Control panel —

KD-AR7500/KD-SHX750	6
Parts identification	6

Remote controller —

RM-RK300	7
Main elements and features	7

Getting started..... 8

Basic operations.....	8
Canceling the display demonstration.....	9
Setting the clock	9

Radio operations 10

Listening to the radio	10
Storing stations in memory.....	11
Listening to a preset station	12

Disc/SD card operations..... 13

Playing a disc in the receiver	13
Playing discs in the CD changer	14
Playing an SD card	15
Other main functions	17
Selecting the playback modes.....	19

Sound adjustments 21

Selecting the DSP modes—DSP	21
Making sound natural	23
Setting the basic sound selection menu —SEL	24
Selecting preset sound modes—EQ	25
Storing your own sound modes	26

Graphic displays..... 27

Basic procedure	27
Downloading the files.....	28
Deleting the files.....	29
Activating the downloaded files	31

General settings — PSM 32

Basic procedure	32
Selecting the dimmer mode	35

Other main functions 36

Assigning titles to the sources	36
Changing the control panel angle	37
Detaching the control panel.....	37

External component operations... 38

Playing an external component.....	38
------------------------------------	----

SIRIUS® radio operations 39

Listening to the SIRIUS® radio.....	40
Storing user channels in memory	41
Listening to a user preset channel.....	41
Selecting a category/channel on the list....	42

Maintenance 44

More about this receiver 45

Troubleshooting 49

Specifications 53

For safety....

- Do not raise the volume level too much, as this will block outside sounds, making driving dangerous.
- Stop the car before performing any complicated operations.

Temperature inside the car....

If you have parked the car for a long time in hot or cold weather, wait until the temperature in the car becomes normal before operating the unit.

How to read this manual

The following methods are used to make the explanations simple and easy-to-understand:

- Some related tips and notes are explained in “More about this receiver” (see pages 45 – 48).
- Button operations are mainly explained with the illustrations as follows:

	Press briefly.
	Press repeatedly.
	Press either one.
	Press and hold until your desired response begins.
	Press and hold both buttons at the same time.

The following marks are used to indicate...

: Built-in CD player operations.

: External CD changer operations.

: SD card operations.

How to forcibly eject a disc

If a disc cannot be recognized by the receiver or cannot be ejected, eject the disc as follows.

- If an SD card is inserted, eject the SD card first (see page 15).

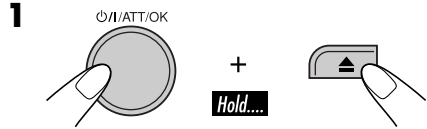

No Eject?
Emergency Eject?

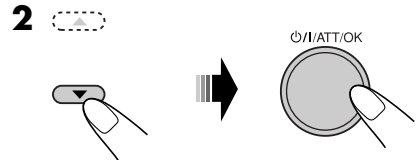

No Eject?
Emergency Eject?

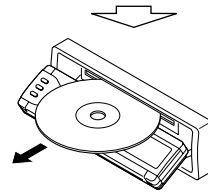

- If this does not work, reset your receiver.
- Be careful not to drop the disc when it ejects.

Caution on volume setting:

Discs produce very little noise compared with other sources. Lower the volume before playing a disc to avoid damaging the speakers by the sudden increase of the output level.

How to change the display pattern

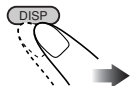

Ex.: When tuner is selected as the source



Source operation screen

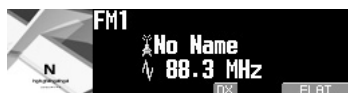

"Small" (CD jacket image) graphic*1 is displayed.

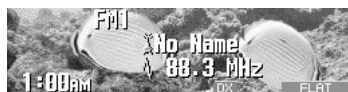

"Large" (full screen size) graphic*1 is shown as the display background.



Graphic screen*1



Audio level meters are displayed (see "LevelMeter" on page 32).

Goes back to the initial display pattern.

- *1 You can use your edited file for graphic screen (see pages 27 – 31). Depending on a downloaded file, it may take longer time to show it on the display.
- *2 The information bar will disappear if no operation is performed.

- If the current source is "SIRIUS," see page 43 for details.

How to enter the various menus

The main menu contains the following menus —MODE, PSM, SEL, PICT, DSP, CCC, TITLE, EQ, and BBE.

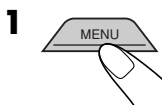

- 2 Move the cursor to select a menu you want (MODE, PSM, SEL, PICT, DSP, CCC, TITLE, EQ, BBE).

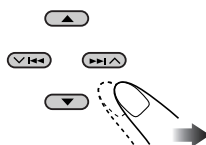

* Cursor

- To go back to the previous screen, press BACK.
- * Works as time countdown indicator.

- 3 Enter the selected menu.



Ex.: When MODE menu is selected

- To go back to the MENU screen, press MENU.

- 4 Operate as instructed on the screen.

Parts identification

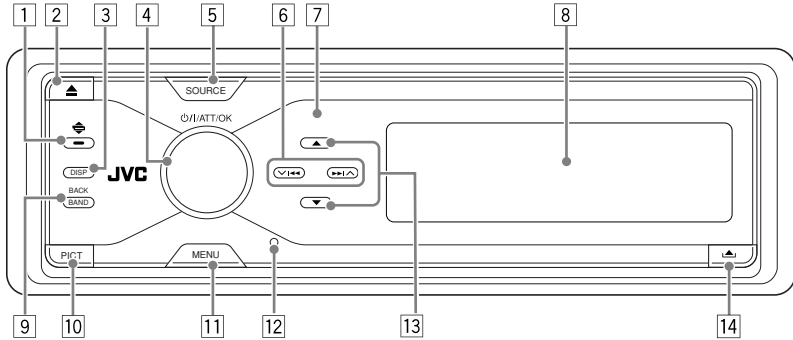

- 1 (angle) button
Adjusts the control panel angle.
- 2 (eject) button
Ejects the disc.
- 3 **DISP (display) button**
Changes the information shown on the display.
- 4 (standby/on/attenuator)/OK button
 - Turns on and off the power and also attenuates the sound.
 - Confirms the selection while operating the menus.**Volume control dial**
Adjusts the volume level.
- 5 **SOURCE button**
Selects the source.
- 6 (V/^) buttons
 - **For FM/AM:** Searches for stations if pressed, or skips frequencies after pressed and held.
 - **For SIRIUS®:** Changes the channels if pressed briefly, or changes the channels rapidly if pressed and held.
 - **For a disc or an SD card:** Changes the tracks if pressed, or fast-forwards or reverses the track if pressed and held.
 - **For menu operations:** Selects the menu items/values.
- 7 **Remote sensor**

DO NOT expose the remote sensor on the control panel to strong light (direct sunlight or artificial lighting).
- 8 **Color display window**
- 9 **BAND/BACK button**
 - **For FM/AM and SIRIUS®:** Selects the band.
 - **For menu operations:** Goes back to the previous screen or cancels the setting.
- 10 **PICT (picture) button**
Displays the PICT menu.
- 11 **MENU button**
Displays the MENU screen.
- 12 **Reset button**
- 13 (up) / (down) buttons
 - **For FM/AM:** Changes the preset stations if pressed, or displays Preset Station List if pressed and held.
 - **For SIRIUS®:** Changes the categories if pressed, or displays Category List if pressed and held.
 - **For MP3/WMA discs or an SD card:** Changes the folders if pressed, or displays Disc List (only for “CD-CH”) or Folder List if pressed and held.
 - **For menu operations:** Selects the menu items/values.
- 14 (control panel release) button

Installing the lithium coin battery (CR2025)

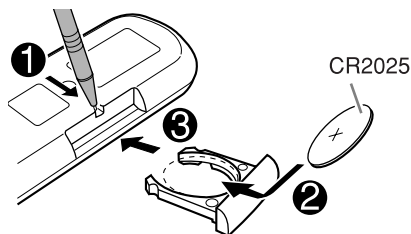

- When operating, aim the remote controller directly at the remote sensor on the receiver. Make sure there is no obstacle in between.

Warning:

- Do not install any battery other than CR2025 or its equivalent; otherwise, it may explode.
- Store the battery in a place where children cannot reach to avoid risk of accident.
- To prevent the battery from over-heating, cracking, or starting a fire:
 - Do not recharge, short, disassemble, or heat the battery or dispose of it in a fire.
 - Do not leave the battery with other metallic materials.
 - Do not poke the battery with tweezers or similar tools.
 - Wrap the battery with tape and insulate when throwing away or saving it.

Caution:

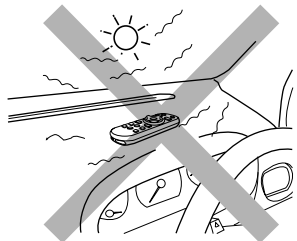

The receiver is equipped with the steering wheel remote control function.

- See the Installation/Connection Manual (separate volume) for connection.

Main elements and features

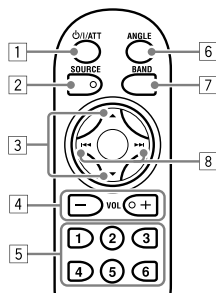

- ⏻/I/ATT (standby/on/attenuator) button**
Turns on and off the power and also attenuates the sound.
- SOURCE button**
Selects the source.
- ▲ (up) / ▼ (down) buttons**
 - **For FM/AM:** Changes the preset stations.
 - **For SIRIUS®:** Changes the categories.
 - **For MP3/WMA discs or an SD card:** Changes the folders.
- VOL (volume) + / - buttons**
Adjusts the volume level.
- Number buttons**
 - **For FM/AM:** Selects the preset station if pressed, or store a station if pressed and held.
 - **For SIRIUS®:** Selects the preset channels if pressed, or store a channel if pressed and held.
 - **For audio CDs or CD Texts:** Selects the tracks.
 - **For MP3/WMA discs or an SD card:** Selects the folders.
 - **For CD changer:** Selects the discs.
- ANGLE button**
Adjusts the control panel angle.
- BAND button**
Selects the band.
- ◀◀ / ▶▶ buttons**
 - **For FM/AM:** Searches for stations if pressed, or skips frequencies after pressed and held.
 - **For SIRIUS®:** Changes the channels if pressed briefly, or changes the channels rapidly if pressed and held.
 - **For a disc or SD card:** Changes the tracks if pressed, or fast-forwards or reverses the track if pressed and held.

Getting started

Basic operations

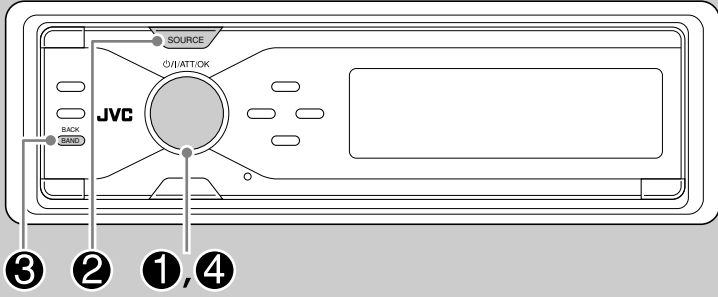

1 Turn on the power.



2

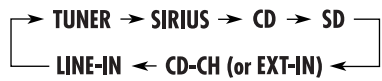
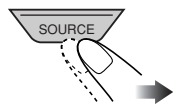

You cannot select some sources if they are not ready.

3

• For FM/AM tuner

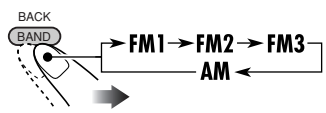

• For SIRIUS® radio

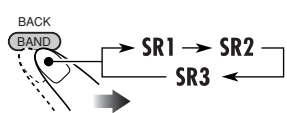

4

Adjust the volume.



5

Adjust the sound as you want.
(See pages 21 – 26.)

To drop the volume in a moment (ATT)



To restore the sound, press it again.

To turn off the power

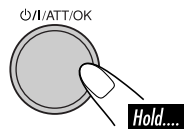

Canceling the display demonstration

If no operations are done for about 45 seconds, display demonstration starts.

[Initial: Demo]—see page 32.

1 Enter the PSM menu (see page 5).

2 Select “Off.”

- Make sure “Demo/Link” is shown on the display. If not, press ▲ or ▼.

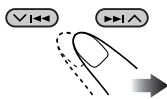

3 Finish the procedure.



To activate the display demonstration

In step **2** above, select “Demo” or “ImageLink.” For more details, see page 32.

Setting the clock

1 Enter the PSM menu (see page 5).

2 Set the hour, minute, and clock system.

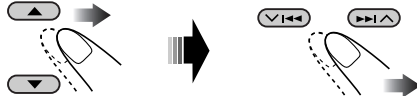

1 Select “Clock Hr” (hour), then adjust the hour.



2 Select “Clock Min” (minute), then adjust the minute.



3 Select “24H/12H,” then select “24H” or “12H.”



3 Finish the procedure.



Radio operations

Listening to the radio

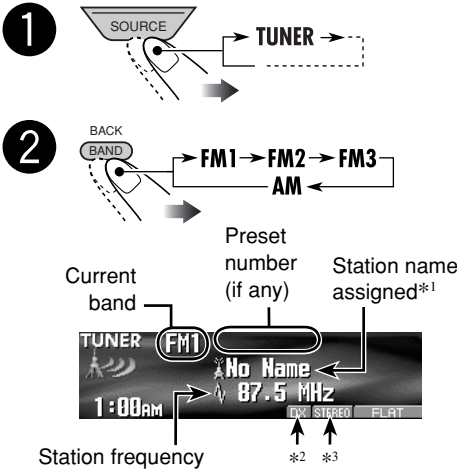
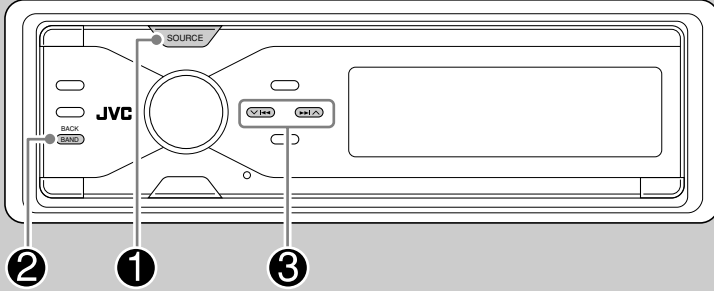

*1 To assign names to the stations, see page 36.

*2 LO or DX indicator: See page 11.

- *3 STEREO or MONO indicator:
- STEREO indicator lights up when receiving an FM stereo broadcast with sufficient signal strength.
 - For MONO, see the right column.

3 Start searching for a station.

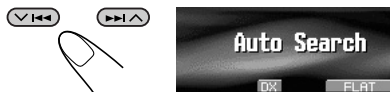

When a station is received, searching stops.

To stop searching, press the same button again.

To tune in to a station manually

In step 3 on the left...



■ When an FM stereo broadcast is hard to receive

1 Enter the MODE menu (see page 5).



2 Select "Mono."

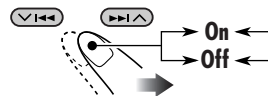

MONO indicator lights up. Reception improves, but stereo effect will be lost.

4 Finish the procedure.



To restore the stereo effect, repeat the same procedure and select “Off” on step 3.

■ To tune in FM stations only with strong signals—LO/DX (Local/Distance-extreme)

If received signals are weak, you may only hear noises. You can make this unit detect only stations with sufficient signal strength while searching for FM stations.

1 Enter the MODE menu (see page 5).

2 Select “LO/DX.”



3 Select “Local.”

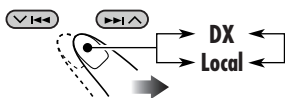

- **DX:** To tune in to all receivable stations. **DX** indicator lights up.
- **Local:** To tune in to only stations with sufficient signal strength. **LO** indicator lights up.

4 Finish the procedure.



Storing stations in memory

You can preset six stations for each band.

■ FM station automatic presetting—SSM (Strong-station Sequential Memory)

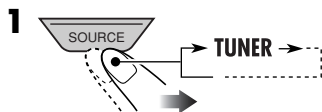

2 Select the FM band (FM1 – FM3) you want to store into.



3 Enter the MODE menu (see page 5).

4 Select “SSM.”

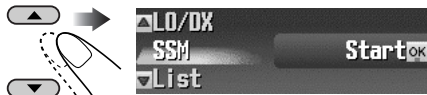

5

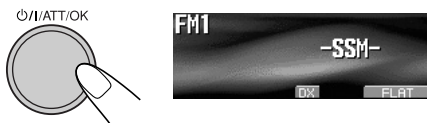

Local FM stations with the strongest signals are searched and stored automatically in the FM band.

To be continued....

Manual presetting

Ex.: Storing FM station of 92.5 MHz into preset number 3 of the FM1 band.

1

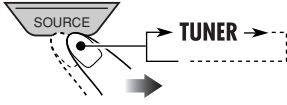

2



- If you hold ▲/▼, the Preset Station List will appear (see step 7 below).

3

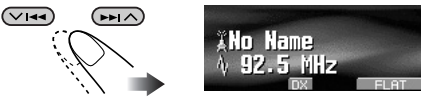

4 Enter the MODE menu (see page 5).

5 Select “List.”



6



7 Select a preset number.



- You can move to the lists of the other FM bands by pressing ◀◀▶▶ (▼/▲).

8 Store the station.



When using the remote controller...

After tuning in to a station you want to preset

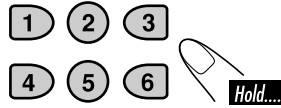

Listening to a preset station

1

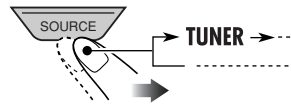

2



3 Perform steps 4 to 7 (on left column) to enter the Preset Station List.

4



When using the remote controller...

To directly select the preset number

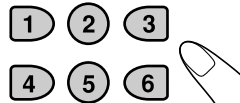

Disc/SD card operations

Playing a disc in the receiver



All tracks will be played repeatedly until you change the source or eject the disc.

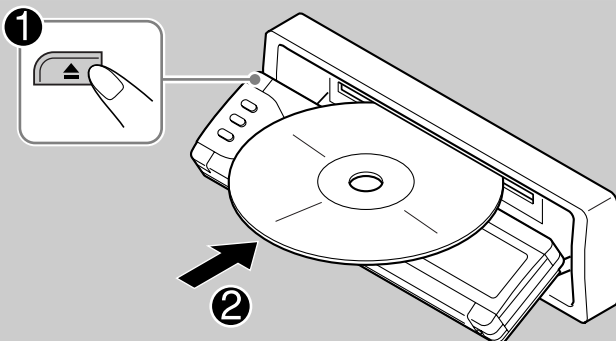

About MP3 and WMA discs

MP3 and WMA (Windows Media® Audio) “tracks” (words “file” and “track” are used interchangeably) are recorded in “folders.”

- When an MP3 or a WMA folder includes an image <jpw> file edited by Image Converter (Color Ver. 2.0)—supplied in the CD-ROM, you can show the image on the display while the tracks in the folder are played back—ImageLink. (See pages 32 and 47 for details.)

- When inserting an audio CD or a CD Text disc:

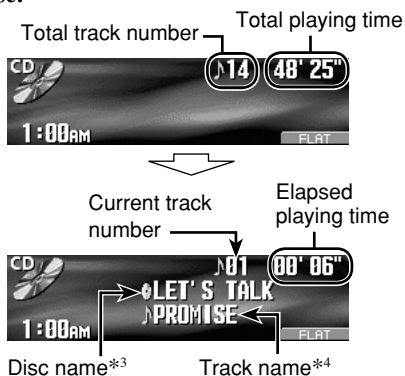

- *1 Either the MP3 or WMA indicator lights up depending on the detected file.
- *2 The album name/performer with indicator and the track title with indicator will appear if “Tag” is set to “On” (see page 33).
- *3 Appears only for CD Texts and CDs if it has been assigned or recorded. (“No Name” appears if no name is recorded or assigned to an audio CD.)
- *4 Appears only for CD Texts. (“No Name” appears if no name is recorded.)

To stop play and eject the disc

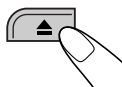

To return the control panel to its previous position, press it again.

- When inserting an MP3 or a WMA disc:

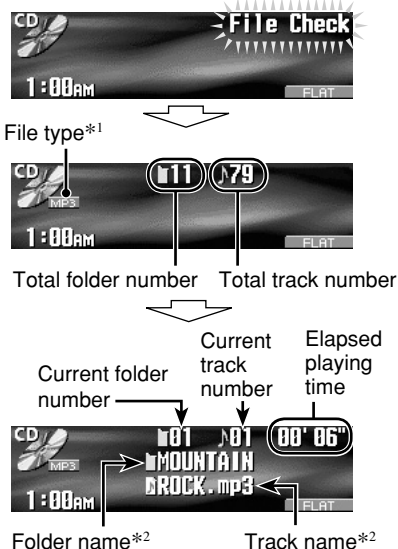

Playing discs in the CD changer

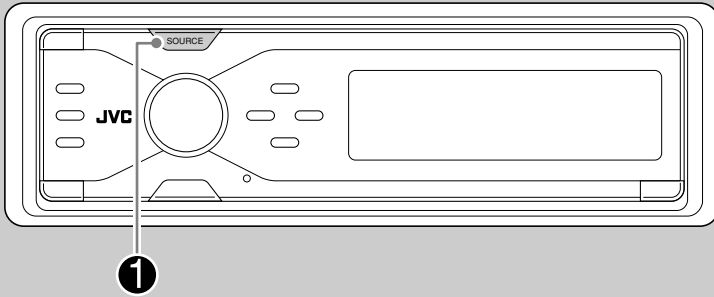

About the CD changer

It is recommended to use the JVC MP3-compatible CD changer with your receiver.

- You can also connect other CH-X series CD changers (except CH-X99 and CH-X100). However, they are not compatible with MP3 discs, so you cannot play back MP3 discs.
- You cannot use the KD-MK series CD changers with this receiver.
- Disc text information recorded in the CD Text can be displayed when a JVC CD Text compatible CD changer is connected.
- You cannot control and play any WMA disc in the CD changer.

All tracks of the inserted discs in the magazine will be played repeatedly until you change the source or eject the magazine from the CD changer.

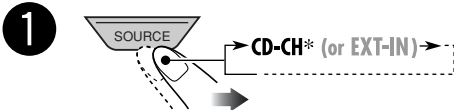

* If you have changed "Ext Input" setting to "Ext Input" (see page 34), you cannot select the CD changer.

- When the current disc is an MP3 disc:

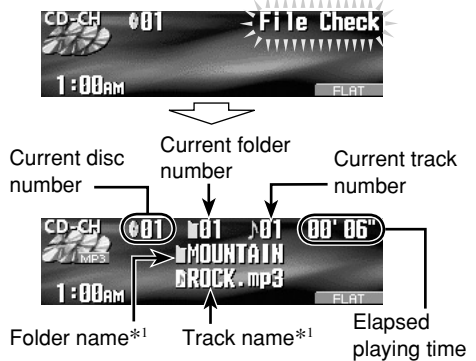

- When the current disc is an audio CD or a CD Text disc:

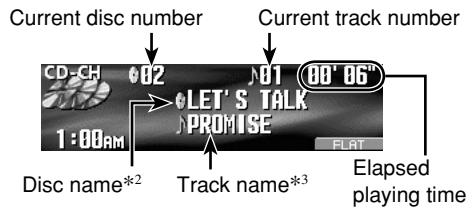

*1 The album name/performer with indicator and the track title with indicator will appear if "Tag" is set to "On" (see page 33).

*2 Appears only for CD Texts and CDs if it has been assigned or recorded. ("No Name" appears if no name is recorded or assigned to an audio CD.)

*3 Appears only for CD Texts. ("No Name" appears if no name is recorded.)

Playing an SD card

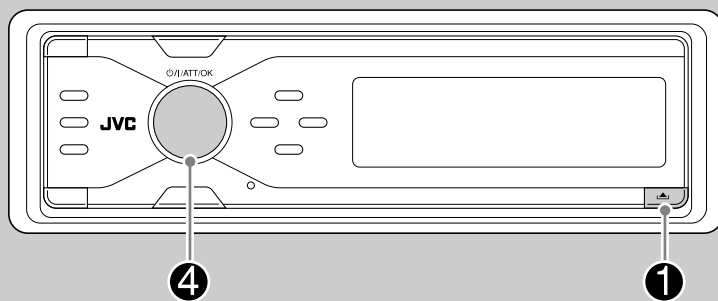

About the SD card

You can play back MP3/WMA tracks recorded on the SD card and show the stored image on the display during playback—ImageLink. (See pages 32 and 47 for details.)

The required SD recording format is FAT 12/16 and the recommended storage type is 8 MB to 512 MB.

- You cannot use MMC or mini SD with this receiver.

Before detaching the control panel, turn off the power.

1 Detach the control panel.

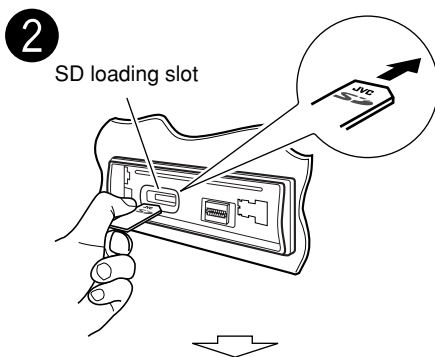
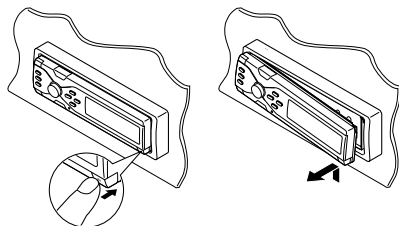

SD loading slot

SD card

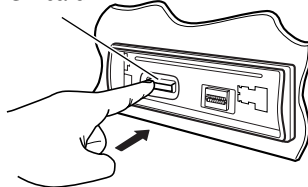

Press in the SD card until you hear a clicking sound.

To eject the SD card, press the SD card again.

- Press the SD card softly (do not release your finger quickly); otherwise the SD card may pop out from the unit.

To be continued....

3 Attach the control panel.

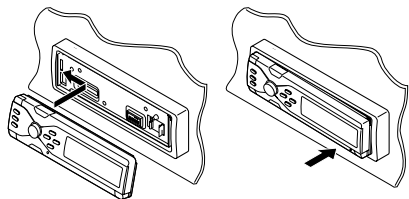

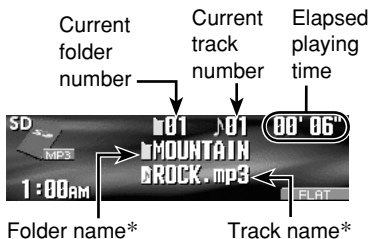
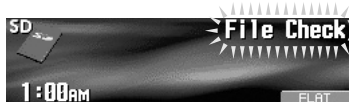

4  • The control panel goes back to the previous position (see page 37).

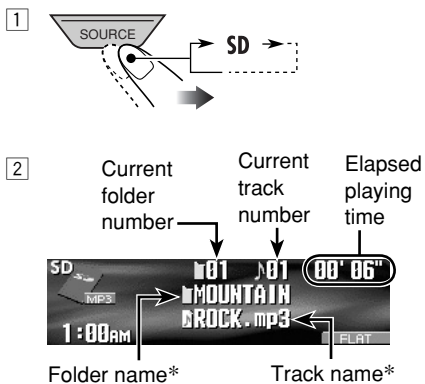

Playback starts automatically if tracks are recorded.

If an SD Card has been loaded...



* The album name/performer with  indicator and the track title with  indicator will appear if "Tag" is set to "On" (see page 33).

To fast-forward or reverse the track

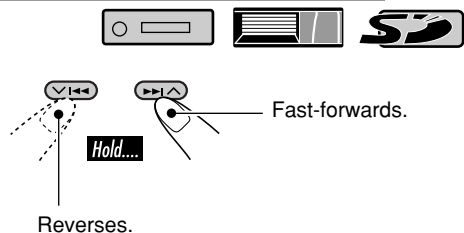

To go to the next or previous tracks

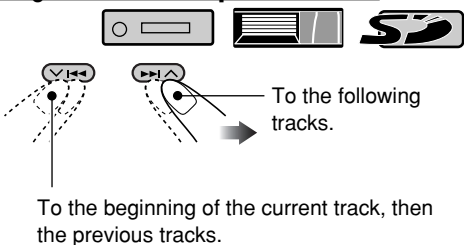





To go to the next or previous folders (only for MP3 and WMA tracks)

For MP3 tracks:  

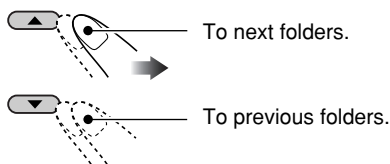

For WMA tracks:  



- Holding the buttons can display the Disc List () and Folder List ( / ) (see the following section).

Other main functions

Selecting a disc/folder/track on the list



- This function is not available for an audio CD or a CD text when the source is “CD.”

1 Enter the MODE menu (see page 5).

2 Select “List.”



3 Select the list type—“Disc,”*1 “Folder,”*2 or “File.”*2

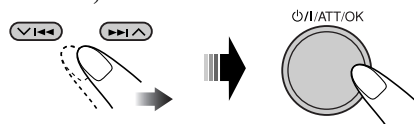

*1 Selectable only when the source is “CD-CH.”

*2 Appears only for MP3/WMA files.

1 When “Disc” is selected:



Disc List appears.

- You can move to the other list by pressing \llcorner / \triangleright (\wedge / \vee).

To select a disc



To be continued....

To start playback



- The Folder List of the selected disc appears in the following cases;
 - if the selected disc is an MP3 disc, and
 - if you select the current disc (highlighted on the screen).

2 When “Folder” is selected:



Folder List appears.

- You can move to the other lists by pressing $\leftarrow \rightarrow$ (\wedge / \vee).

To select a folder



To start playback



- If you select the current folder (highlighted on the screen), its File List appears.

3 When “File” is selected:

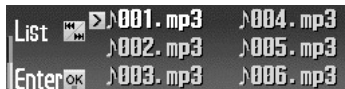

File List appears.

- You can move to the other lists by pressing $\leftarrow \rightarrow$ (\wedge / \vee).

To select a file



To start playback



When using the remote controller...



- To directly select a disc ()
- To directly select a track of an audio CD or a CD Text ()
- To directly select an MP3/WMA folder (/)

To select a number from 1 – 6:

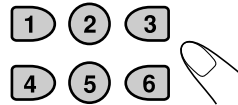

To select a number from 7 (1) – 12 (6):

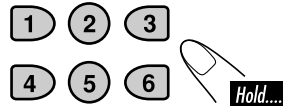

- For MP3/WMA folders:
It is required that folders are assigned with 2-digit number at the beginning of their folder names—01, 02, 03, and so on.

Prohibiting disc ejection

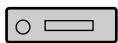

You can lock a disc in the loading slot.

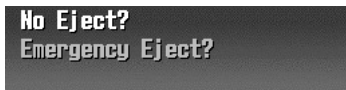
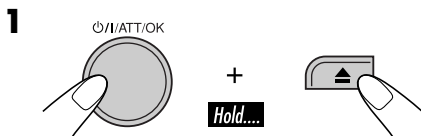

2 After making sure “No Eject?” is selected (highlighted)...



“No Eject?” flashes, and the disc cannot be ejected.

To cancel the prohibition

Repeat the same procedure, press **⏻/ATT/OK** in step **2** after making sure that “Eject OK?” is selected (highlighted).
“Eject OK” flashes.

Selecting the playback modes



You can use only one of the following playback modes at a time.

1 Enter the MODE menu (see page 5).

2 Select one of the playback modes—“Intro,” “Repeat,” or “Random.”



3 Select your desired playback modes.

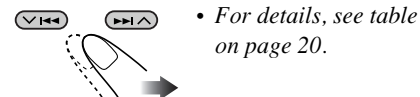

4 Finish the procedure.



Intro play



Ex.: When "Track Intro" is selected while playing an MP3 disc in the receiver

Mode Plays the beginning 15 seconds of...

- Track:** All tracks of the current disc or the SD card.
- While playing, **INTRO** lights up.
- Folder*1:** First tracks of all folders of the current disc or the SD card.
- While playing, **INTRO** lights up.
- Disc*2:** First tracks of all the inserted discs.
- While playing, **INTRO** lights up.
- Off:** Cancels.

Repeat play



Ex.: When "Track Repeat" is selected while playing an MP3 disc in the receiver

Mode Plays repeatedly

- Track:** The current track.
- While playing, **REPEAT** lights up.
- Folder*1:** All tracks of the current folder.
- While playing, **REPEAT** lights up.
- Disc*2:** All tracks of the current disc.
- While playing, **REPEAT** lights up.
- Off:** Cancels.

Random play



Ex.: When "Disc Random" is selected while playing an MP3 disc in the receiver

Mode Plays at random

- Folder*1:** All tracks of the current folder, then tracks of the next folder and so on.
- While playing, **RANDOM** lights up.
- Disc:** All tracks of the current disc.
- While playing, **RANDOM** lights up.
- SD:** All tracks of the SD card.
- While playing, **RANDOM** lights up.
- All*2:** All tracks of the inserted discs.
- While playing, **RANDOM** lights up.
- Off:** Cancels.

*1 Only while playing an MP3 (/ /) or a WMA (/) track.

*2 Only while playing a disc in the CD changer ().

Selecting the DSP modes—DSP

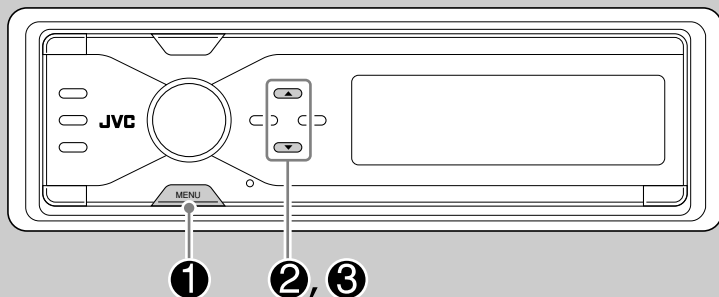

You can create a more acoustic sound field such as in a theater, hall, etc.

Available DSP modes

Defeat (No DSP mode is applied)
Theater, Hall, Club, Dome, Studio,
V.Cancel (Voice Cancel: Reduces the vocal sounds. Good for mastering your favorite songs—Karaoke.)

3 Adjust the effect level (1 – 3).



The selected DSP effect level is valid for all DSP modes except “V.Cancel.”

- As the number increases, the effect level becomes stronger.

1 Enter the DSP menu (see page 5).

2 Select one of the DSP modes.



Ex.: When “Theater” is selected

- To finish the procedure

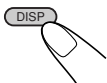

- To adjust the effect level



→ Go to step 3.

- To finish the procedure

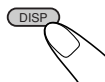

- To make further precise settings



→ See page 22.

To cancel the DSP modes, select “Defeat” in step 2.

To be continued...

To make further precise settings for the DSP modes

These settings you make are valid for all DSP modes except “V.Cancel.”

Setting items:

The number of the built-in speakers:

Select the number of the speakers built in your car—“2ch” or “4ch.”

- When you have four speakers (4ch) built in your car, select your car size (see step 4 that follows).

Listening seat position:

Select the listening seat position where you want to locate the sound image.

- Repeat steps 1 to 3 on page 21 to select DSP mode (except “V.Cancel”).



- Select the number of the built-in speakers.

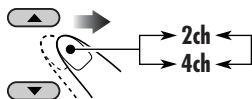

2ch: Select for the two speaker system.

4ch: Select for the four speaker system.

-
-
-



- If you select “2ch,” go to step 5.

- If you select “4ch,” select your car size.

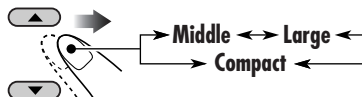

Middle: Select when the distance from the rear speakers to the listening seat position is almost equal to that from the front speakers.

Large: Select when the distance from the rear speakers to the listening seat position is longer than that from the front speakers.

Compact: Select when the distance from the rear speakers to the listening seat position is shorter than that from the front speakers.

- Select your listening seat position.



All: For all front and rear seats.

Front: For the both front seats.

R.Front: For the front right seat.

L.Front: For the front left seat.

- Finish the procedure.



Making sound natural

To activate Compression Compensative (CC) Converter

CC Converter eliminates jitter and ripples, achieving a drastic reduction in digital distortion. This processing can be applied to the analog sources as well as the digital sources; therefore, you can obtain a natural sound field from any source.

1 Enter the CCC menu (see page 5).

2 Select “On.”

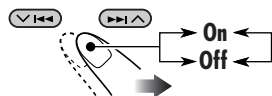

- When “C.C.Conv.” is turned on, the CCC indicator is brightened in yellow on the display.
- **To cancel CC Converter**, select “Off.”

3 Finish the procedure.



To activate BBE Digital

BBE Digital* is a digital processing method to restore the brilliance and clarity of the original live sound in recording, broadcasts, etc. When a speaker reproduces sound, it introduces frequency-dependent phase shifting, causing high-frequency sounds to take longer to reach the ear than low frequency sounds. BBE Digital adjusts the phase relationship between the low, mid and high frequencies by adding a progressively longer delay time to the low and mid frequencies, so that all frequencies reach the listener’s ears at the proper time.

1 Enter the BBE menu (see page 5).

2 Select the effect level.

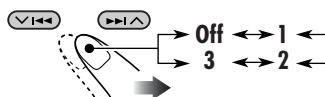

Ex.: When “1” is selected

- As the number gets higher, the effect level becomes stronger. When “BBE” is turned on, the BBE indicator is brightened in green (with its current level) on the display.
- **To cancel BBE Digital**, select “Off.”

3 Finish the procedure.



* Manufactured under license from BBE Sound, Inc.
Licensed by BBE Sound, Inc. under USP4638258, 5510752 and 5736897. BBE and BBE symbol are registered trademarks of BBE Sound, Inc.

Setting the basic sound selection menu—SEL

You can adjust the sound characteristics to your preference.

1 Enter the SEL menu (see page 5).

2 Select a setting item—"Fad/Bal," "Subwoofer," or "VolAdjust."



Ex.: When "Fad/Bal" is selected

When selecting "Fad/Bal" and "Subwoofer," press **⏻/I/ATT/OK** to enter the selected menu.

3 Adjust the selected setting item.

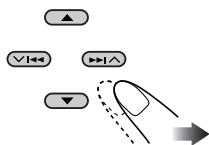

- To adjust other SEL settings, press **BACK**.

4 Finish the procedure.



To adjust fader and balance—Fad/Bal



Adjust the fader—speaker output balance between the front and rear speakers.

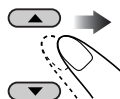

- Upmost—front only
- Downmost—rear only

Adjust the balance—speaker output balance between the left and right speakers.

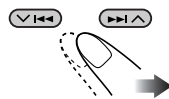

- Leftmost—left only
- Rightmost—right only

To adjust subwoofer output—Subwoofer



Select an appropriate cutoff frequency level according to the subwoofer connected.

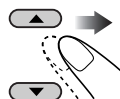

- 55Hz / 85Hz / 115Hz

- Frequencies higher than the selected level are cut off to the subwoofer.

Adjust the subwoofer output level.

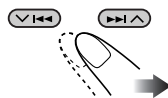

- 0 (min.) to 8 (max.)

To adjust the input level of each source—VolAdjust



This setting is required for each source except FM. Before making an adjustment, select an appropriate source for which you want to make an adjustment.

Once you have made an adjustment, it is memorized, and the volume level will automatically increase or decrease by adjusted level whenever you change the source.

Adjust to match the input level to the FM sound level.

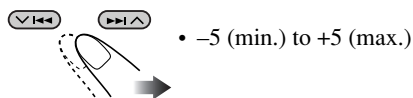

Selecting preset sound modes—EQ

You can select a preset sound mode suitable to the music genre.

Available sound modes

Flat (No sound mode is applied),
Hard Rock, R&B (Rhythm&Blues),
Pop, Jazz, Dance, Country, Reggae,
Classic, User 1, User 2, User 3

- 1 Enter the EQ menu (see page 5).
- 2 Select a sound mode.

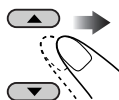

Ex.: When "Flat" is selected

- 3 Finish the procedure.

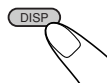

Storing your own sound modes

You can adjust the sound mode and store your own adjustments in memory.

1 Enter the EQ menu (see page 5).

2 Select a sound mode (see step 2 on page 25).

3 

4 Make adjustments as you like.

1 Select the frequency band — 60 Hz, 150 Hz, 400 Hz, 1 kHz, 2.4 kHz, 6 kHz, 12 kHz.





2 Adjust the level of the selected band within the range of -05 to +05.



3 Repeat steps 1 and 2 to adjust the other frequency bands.

5 Store the adjustments.

1  

2 Select one of the user modes— User 1/2/3.

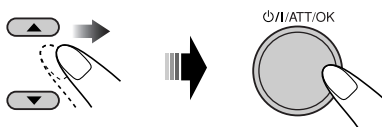

Ex.: When “User 1” is selected

The list below shows the preset frequency level settings for each sound mode:

Sound Mode	Preset equalizing values						
	60 Hz	150 Hz	400 Hz	1 kHz	2.4 kHz	6 kHz	12 kHz
Flat	00	00	00	00	00	00	00
Hard Rock	+03	+03	+01	00	00	+02	+01
R&B	+03	+02	+02	00	+01	+01	+03
Pop	00	+02	00	00	+01	+01	+02
Jazz	+03	+02	+01	+01	+01	+03	+02
Dance	+04	+02	00	-02	-01	+01	+01
Country	+02	+01	00	00	00	+01	+02
Reggae	+03	00	00	+01	+02	+02	+03
Classic	+02	+03	+01	00	00	+02	00
User 1	00	00	00	00	00	00	00
User 2	00	00	00	00	00	00	00
User 3	00	00	00	00	00	00	00

Basic procedure

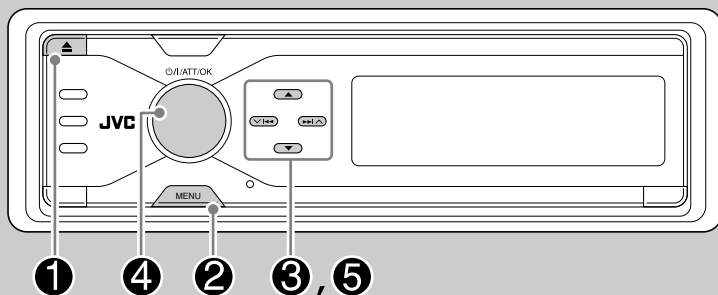

Before starting the following procedure, prepare a CD-R or an SD card including still images (pictures) and animations (movies).

- With Image Converter (Color Ver. 2.0) included in the supplied CD-ROM, you can create your own images and animations. (Samples are included in the CD-ROM.)
- You can store two sizes of picture and animation—“Large” and “Small” as the graphic display (see page 5).

3 Select the picture size—“Large” or “Small.”

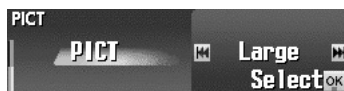
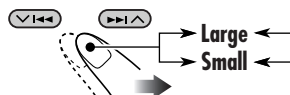

4  Press the OK button.



5 Select the item.



Ex.: When “Delete” is selected

1 Insert a CD-R, an SD card, or the supplied CD-ROM.

- CD-R/supplied CD-ROM

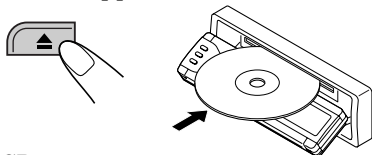

- SD card

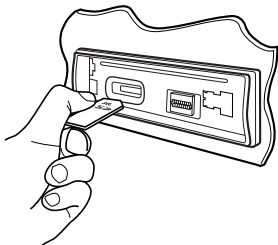

2 Enter the PICT menu (see page 5).

- If you press PICT, you can enter the PICT menu directly.

- To download the file(s):
➔ “Download” (see page 28)
- To delete the file(s):
➔ “Delete” (see page 29)
- To delete all files:
➔ “AllDelete” (see page 30)
- To activate the file(s):
➔ Activating the downloaded files (see page 31)

IMPORTANT:

- Refer also to Image Converter PDF files included in the “Manual” folder on the supplied CD-ROM.
- Still images (pictures) and animations (movie) should have the following extension code in their file names:
 - **.jpl**: for large size still images
 - **.jpm**: for small size still images
 - **.jpa**: for large size animations
 - **.jpb**: for small size animations
 - **.jpw**: for ImageLink (see pages 32 and 47)
- Before you download or delete the files, observe the following:
 - Do not download a file while driving.
 - Do not turn off the ignition key of the car while downloading or deleting a file.*
 - Do not detach the control panel while downloading or deleting a file.*

* If you do so, the file download or deletion will not be done correctly.

Downloading the files

- **Picture:** Graphic screen
To download/delete still images (16 still images each for large size and for small size) which will be shown while playing a source.
- **Movie:** Graphic screen
To download/delete animations (60 frames each for large size and for small size) which will be shown while playing a source.

■ Downloading pictures or animations

- It takes a long time to download an animation. For details, see page 48.
- To activate the downloaded files, see page 31.

1 Follow steps ① to ⑤ on page 27.

- In step ③, select the picture size.
- Then in step ⑤, select “Download.”

2 Select the file type—either “Picture” or “Movie.”

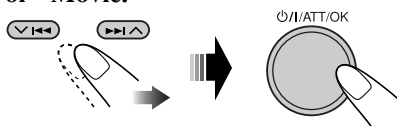

The Folder List appears.

3 Select a folder.

- You can move to the other lists by pressing ◀▶▶▶ (▽/△).

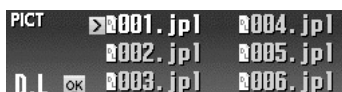
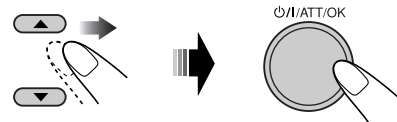

The File List appears.

4 Select a file.

- You can move to the other lists by pressing ◀▶▶▶ (▽/△).

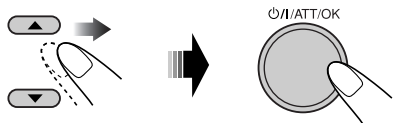

5 Download the file.



- To cancel downloading, press DISP.
- When download is complete, the File List appears again.

6 • To download more pictures from the same folder, repeat steps 4 and 5.

- To download more pictures from another folder, press BACK. Then, repeat steps 3 to 5.

7 Finish the procedure.

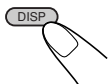

Deleting the files

Deleting the stored pictures and animations

1 Follow steps 1 to 5 on page 27.

- In step 3, select the picture size.
- Then in step 5, select “Delete.”

2 Select the file type—either “Picture” or “Movie.”

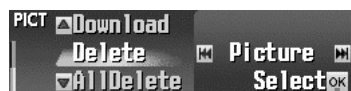
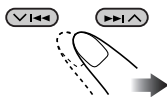

Ex.: When “Picture” is selected

3 • To delete the stored pictures



2 Select “Delete.”

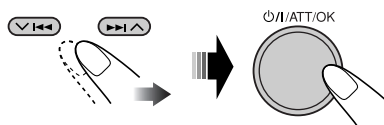

The File List appears.

3 Select a file.

- You can move the other lists by pressing \leftarrow/\rightarrow (\checkmark/\wedge).

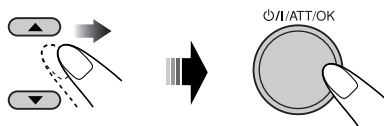

4



- When a file is deleted, the File List appears again.

5 Repeat steps 3 and 4 to delete more pictures.

To be continued...

• To delete the stored animation



• When the movie is deleted, the PICT menu appears again.

4 Finish the procedure.

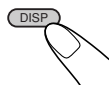

■ Deleting all the stored pictures and animations for each size

To delete all the stored pictures

You can delete all stored pictures of each size (“Large” or “Small”).

- Follow steps 1 to 5 on page 27.
 - In step 3, select the picture size.
 - Then in step 5, select “Delete.”

2 Select “Picture.”

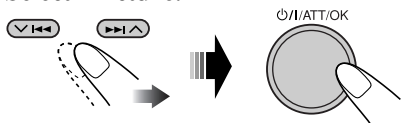

3 Select “AllDelete.”

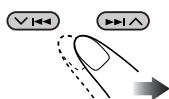

• When all pictures are deleted, the PICT menu appears again.

6 Finish the procedure.

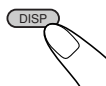

To delete all the stored files

You can delete all stored pictures and animations of each size (“Large” or “Small”).

- Follow steps 1 to 5 on page 27.
 - In step 3, select the picture size.
 - Then in step 5, select “AllDelete.”



• When all files are deleted, the PICT menu appears again.

4 Finish the procedure.

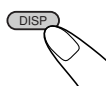

Activating the downloaded files

1 Enter the PSM menu (see page 5).

2 Select “PICT.”



3 Select the picture size you want to activate—“Large” or “Small.”

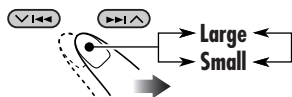

4 \odot /ATT/OK

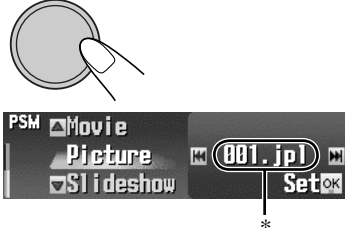

* If there is no still images or animation downloaded, you can only select “Default.”

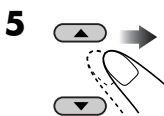

Picture: One of your edited still images stored in “Picture” is activated.
 ➔ Go to step **6**.

Slideshow: All stored still images are activated and shown in sequence (UserSlide).
 ➔ Go to step **7**.

Movie: Your edited animation stored in “Movie” is activated.
 ➔ Go to step **6**.

6 Select a file.



- For “Movie,” select either “Default” or “UserMovie.” (If no animation is stored, you can only select “Default.”)

7 Finish the procedure.

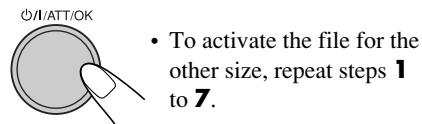

General settings — PSM

Basic procedure

You can change PSM (Preferred Setting Mode) items listed in the table that follows.

1 Enter the PSM menu (see page 5).

2 Select a PSM item.

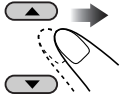

Ex.: When “Scroll” is selected

3 Adjust the setting.

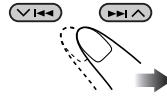

4 Repeat steps 2 and 3 to adjust the other PSM items if necessary.

5 Finish the procedure.



Indications	Selectable settings, [reference page]
Demo/Link Display demonstration	Demo: [Initial]; Display demonstration (animation) appears. ImageLink: To show a still image while playing back an MP3/WMA track, [13, 15, 47]. Off: Cancels. • These graphics appear if no operation is done for about 45 seconds.
WallPaper Wall paper	You can select the background screen of the display window. Standard 1 [Initial] Standard 2 Standard 3 (back to the beginning)
LevelMeter Audio level meter	You can select the level meter. Meter1 [Initial] Meter2 Meter3 (back to the beginning) • Press DISP repeatedly to show the selected level meter.
PICT Pictures	You can activate the graphic screen using either movie or picture, [31]. Select the picture size first. Large: [Initial]; 256 x 64 pixel (full screen size) Small: 64 x 64 pixel (CD jacket image) After select the picture size, you can select one of the following items separately for “Large” and “Small.” Picture: [Initial]; One of your edited still images stored in “Picture” is activated. Slideshow: All stored still images are activated and shown in sequence (UserSlide). Movie: Your edited animation stored in “Movie” is activated. • Press DISP repeatedly to show the selected graphics.

Indications	Selectable settings, [reference page]
Clock Hr Clock hour	1 – 12 (0 – 23), [9] [Initial: 1 (1:00 AM)]
Clock Min Clock minute	00 – 59, [9] [Initial: 00 (1:00 AM)]
24H/12H Clock system	12H (Hours) ⇄ 24H (Hours), [9] [Initial: 12H]
Clock Adj *1 Automatic clock adjustment	Auto: [Initial]; The built-in clock is automatically adjusted using the clock time data provided via the SIRIUS® radio channel. Off: Cancels.
Time Zone *1, *2 Time zone	Select your residential area from the following time zones for clock adjustment. Eastern [Initial] ⇄ Atlantic ⇄ NewfndIn (Newfoundland) ⇄ Alaska ⇄ Pacific ⇄ Mountain ⇄ Central ⇄ (back to the beginning)
DST *1, *2 Daylight saving time	Activates this if your residential area is subject to DST. On: [Initial]; Activates daylight saving time. Off: Cancels.
Scroll Scroll mode	The entire text information can be shown by scrolling if it cannot be shown at a time. Once: [Initial]; Scrolls only once. Auto: Repeats scrolling (in 5-second intervals). Off: Cancels. • Holding DISP for more than one second can scroll the display regardless of the setting.
Dimmer Dimmer mode	Auto: [Initial]; Dims the display when you turn on the headlights. Time Set: Sets the timer for dimmer, [35]. Off: Cancels. On: Activates dimmer.
From-To *3 Dimmer time	Any hour – Any hour, [35] [Initial: 6PM – 7AM]
Bright Brightness	1 – 8: Adjust the display brightness to make the display indications clear and legible. [Initial: 8]
Tag Tag display	On: [Initial]; To show the ID3 tag display while playing MP3/WMA tracks, [13, 14, 16]. Off: Cancels.

*1 Displayed only when SIRIUS radio is connected.

*2 Displayed only when “Clock Adj” is set to “Auto.”

*3 Displayed only when “Dimmer” is set to “Time Set.”

Indications	Selectable settings, [reference page]
IF Filter Intermediate frequency filter	Auto: <i>[Initial]</i> ; Increases the tuner selectivity to reduce interference noises between the stations. (Stereo effect will be lost.) Wide: Subject to the interference noises from adjacent stations, but sound quality will not be degraded. (Stereo effect will not be lost.)
Sirius ID * ¹ SIRIUS® ID	The 12-digit SIRIUS identification number is shown on the display, [39].
Area Tuner channel interval	US: <i>[Initial]</i> ; Select this when using the receiver in North or South America. (FM: 200 kHz; AM: 10 kHz) Europe: Select this when using the receiver in an area other than North and South America. (FM: 50 kHz—manual tuning, 100 kHz—auto search; AM: 9 kHz)
Ext Input * ² External input	Changer: <i>[Initial]</i> ; To use a JVC CD changer and/or SIRIUS radio (JVC DLP), [14, 39]. Ext Input: To use any external component other than above, [38].
Beep Key-touch tone	On: <i>[Initial]</i> ; Activates the key-touch tone. Off: Deactivates the key-touch tone.
Telephone * ³ Telephone muting	Muting1/Muting2: Select either one which mutes the sounds while using the cellular phone. Off: <i>[Initial]</i> ; Cancels. <ul style="list-style-type: none"> • If CD or CD changer has been selected as the source, playback pauses during telephone muting.
Amp Gain Amplifier gain control	You can change the maximum volume level of this receiver. HighPower: <i>[Initial]</i> ; Volume 00 – Volume 50 Low Power: Volume 00 – Volume 30 (Select this if the maximum power of the speaker is less than 52 W to avoid damaging the speakers.) Off: Deactivates the built-in amplifier.

*¹ Displayed only when SIRIUS radio is connected.

*² Cannot be selected if the source is “CD-CH,” “EXT-IN,” or “Sirius.”

*³ Only for KD-AR7500.

Selecting the dimmer mode

You can dim the display at night or as you set the timer.

1 Enter the PSM menu (see page 5).

2 Select “Dimmer.”

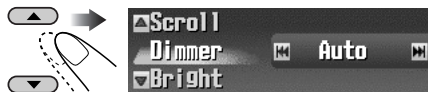

3 Select a setting.

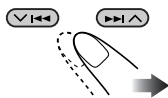

Auto: Dims the display when you turn on the headlights.
 → Go to step **6**.

Time Set: Sets the timer for dimmer.
 → Go to step **4**.

Off: Cancels.
 → Go to step **6**.

On: Always dims the display.
 → Go to step **6**.

4 Enter the Time Set screen.

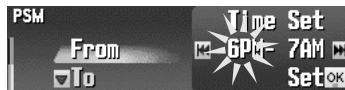

5 Adjust the dimmer time.

1 Set the dimmer start time.

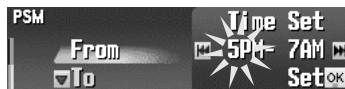
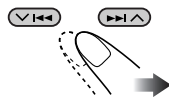

2 Set the dimmer end time.

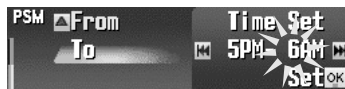
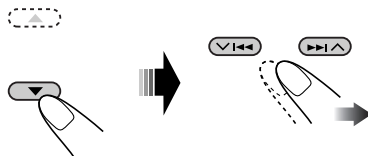

6 Finish the procedure.



Other main functions

Assigning titles to the sources

You can assign titles to station frequencies, CDs (both in this receiver and in the CD changer), and the external components.

Sources	Maximum number of characters
Station frequencies	Up to 16 characters (up to 30 station frequencies including both FM and AM)
CDs/CD-CH*	Up to 32 characters (up to 30 discs)
External components	Up to 16 characters

* You cannot assign a title to a CD Text or an MP3/WMA disc.

1 Select the source.

- For FM/AM tuner: Select a station.
- For a CD in this receiver: Insert a CD.
- For CDs in the CD changer: Select “CD-CH,” then select a disc number.
- For external components: Select “EXT-IN” or “LINE-IN” (see page 38).

2 Enter the TITLE menu (see page 5).

3 Assign a title.

1 Select a character set.

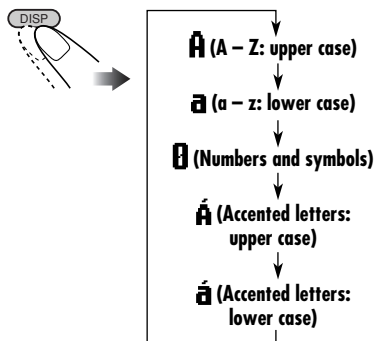

Ex.: When you assign a title to a CD

2 Select a character.

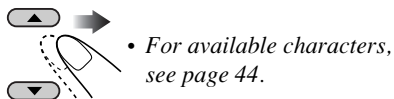

3 Move to the next (or previous) character position.

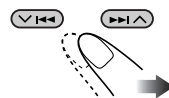

4 Repeat steps 1 to 3 until you finish entering the title.

4 Finish the procedure.



- To cancel the title entry without registration, press MENU.

To erase the entire title

In step 3 on the left...



Changing the control panel angle

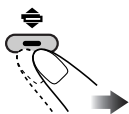

The control panel changes its angle as follows:

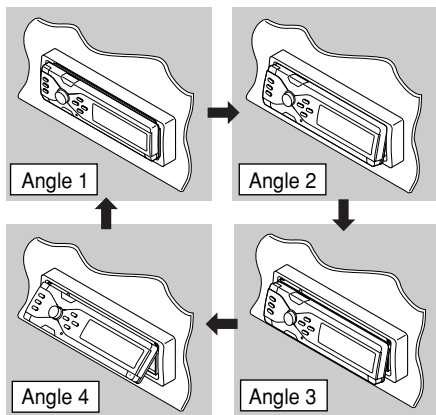

When using the remote controller...

ANGLE



Caution:

Do not insert your finger behind the control panel.

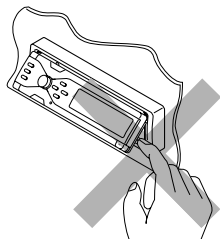

Detaching the control panel

When detaching or attaching the control panel, be careful not to damage the connectors on the back of the control panel and on the panel holder.

Detaching the control panel

Before detaching the control panel, be sure to turn off the power.

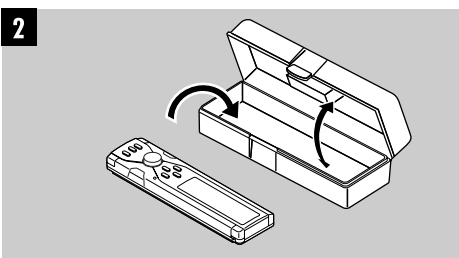
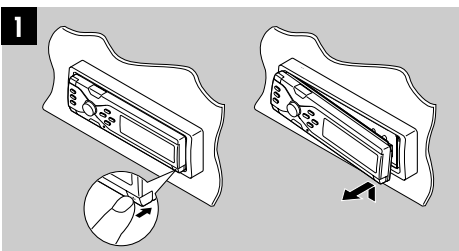

Attaching the control panel

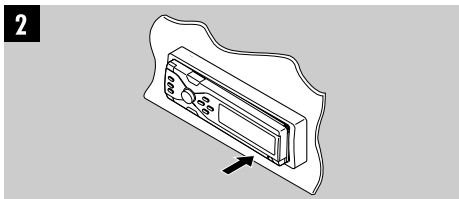
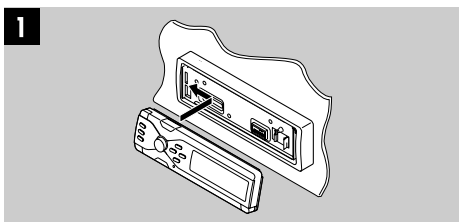

External component operations

Playing an external component

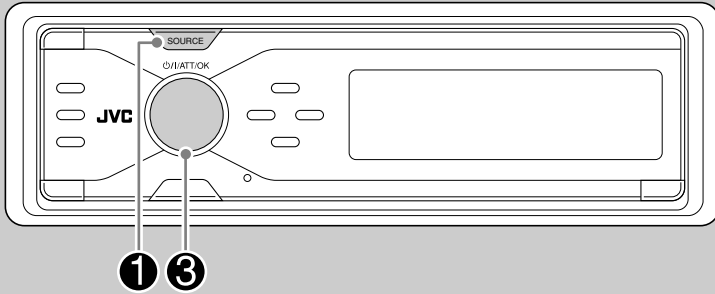

You can connect an external component to the LINE IN plugs on the rear.

You can also connect an external component to the CD changer jack on the rear using the Line Input Adapter KS-U57 (optionally purchased) or Aux Input Adapter KS-U58 (optionally purchased).

Before operating the external component, select the external input correctly (see page 34).

- For connection, see Installation/Connection Manual (separate volume).

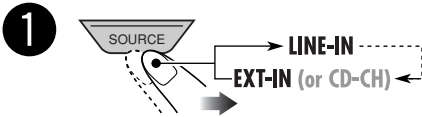

LINE-IN: For selecting the external component connected to the LINE IN plugs.



EXT-IN: For selecting the external component connected to the CD changer jack.

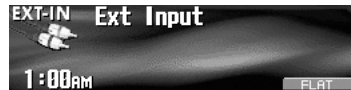

- If you have changed the “Ext Input” setting to “Changer” (see page 34), you cannot select “EXT-IN.”

2 Turn on the connected component and start playing the source.

3 Adjust the volume.



4 Adjust the sound as you want. (See pages 21 – 26.)

About SIRIUS radio

SIRIUS is a satellite radio that can deliver digital-quality sound.

SIRIUS has 65 music channels which are all commercial-free, 50 channels of sports, news, and entertainment programs.

You can enjoy and control the SIRIUS radio digital entertainment channels from the receiver by connecting the JVC SIRIUS radio DLP—Down Link Processor (optionally purchased) to the CD changer jack on the rear.

GCI (Global Control Information) update:

- If channels are updated after subscription, updating starts automatically. “Channels Updating XX%* Completed” appears and no sound can be heard.
- Update takes a few minutes to complete.
- Do not press any button or perform any operation until updating has been completed.

Before operating your SIRIUS radio:

- For connection, see Installation/Connection Manual (separate volume).
- Refer also to the Instructions supplied with your SIRIUS radio.

* Changes every 20% of update until completed (ex. 20%, 40%, 60%).

Before you can listen to JVC DLP, activate your SIRIUS subscription after connection:

- If the power is turned off before subscription is completed, repeat the procedure from beginning.

1 Turn on the power.



2

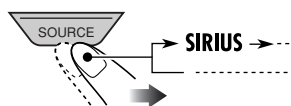

JVC DLP starts updating all the SIRIUS channels. (See GCI update on the left column.)

- Once completed, JVC DLP tunes in to the preset channel, CH184 (channel for subscription guidance).

3 Check your Sirius ID, see page 34.

- ### 4 Contact SIRIUS on the internet at <<http://activate.siriusradio.com/>> to activate your subscription, or you can call SIRIUS toll-free at 1-888-539-SIRIUS (7474). “Subscription Updated Press Any Key to Continue” appears on the display once subscription has been completed.

When you update subscription or change your subscription plan, follow the procedure above.

- However, JVC DLP does not tune in to CH184 this time. Tune in to CH184 manually for updating your subscription.

Listening to the SIRIUS® radio

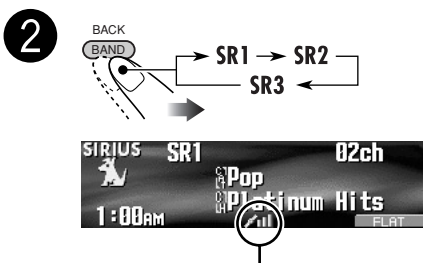
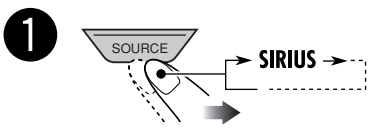
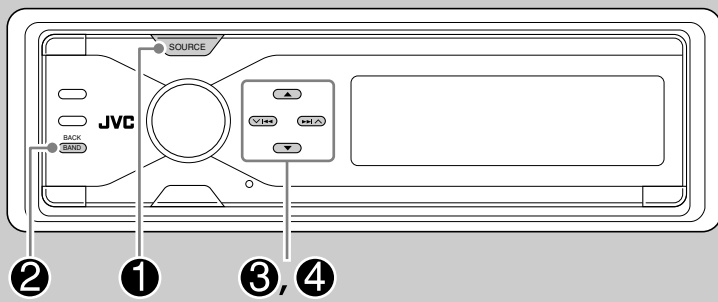

Signal strength bar
(See page 48.)

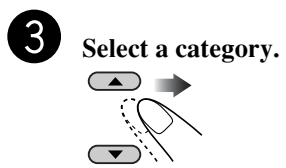

Selecting a particular category (SPORTS, ENTERTAINMENT, etc.) allows you to enjoy only the channels from the selected category.

- You can tune in to all the channels of every category by selecting “ALL.”
- Holding the button displays the category list (see page 42).

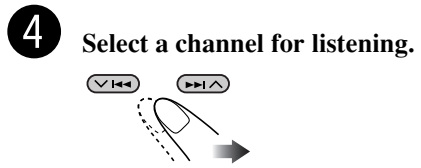

Holding the button changes the channels rapidly.

Storing user channels in memory

You can preset six channels for each band.

Ex.: Storing a channel into preset number 4.

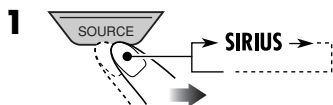

- Holding the button displays the User Preset Channel List (see step **6** on the right column).

3 Enter the MODE menu (see page 5).

4 Select “Preset.”

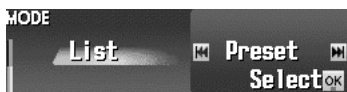
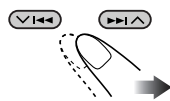

6 Select a user preset number.

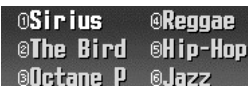
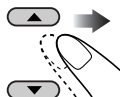

- You can move to the lists of the other SIRIUS bands by pressing $\lll \lll \ggg \ggg$ (\vee / \wedge).

7 Store the channel.



Listening to a user preset channel

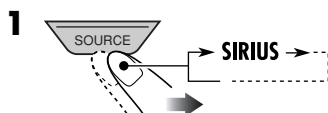

- Holding this button displays the User Preset Channel List (see step **6** above).

3 Perform steps **3** to **6** (above) to select a user preset channel.

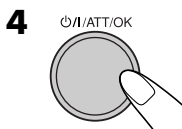

Selecting a category/channel on the list

1 Enter the MODE menu (see page 5).

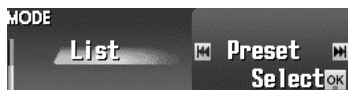

2 To select a category

- Holding ▲/▼ also shows the Category List while listening to a channel.

1 Select “Category.”

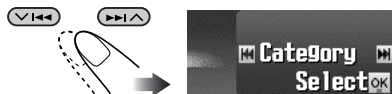

2 ○/I/ATT/OK



- You can move to the other lists by pressing ◀◀/▶▶ (▼/▲).

The first channel of the selected category is tuned in.

- If you select the current category (highlighted on the display), its channel list appears.
- You cannot select the category if all channels in the category is skipped. To restore the skipped category, add (restore) a skipped channel in the skipped category (see page 43).

To select a channel

1 Select “Channel.”

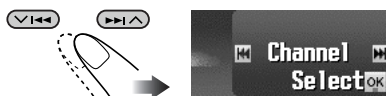

2 ○/I/ATT/OK



- You can move to the other lists by pressing ◀◀/▶▶ (▼/▲).
- You cannot select a channel if it is skipped. To restore the skipped channel, see page 43.

Selecting your favorite from the list

While displaying the Channel List or User Preset Channel List (see the left column)...

1 Enter the list information mode.



One of the channel list below appears.

2

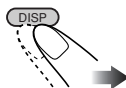

Channel List (Channel name)



Channel List (Artist name)



Channel List (Song title)

3 Select an item.



Ex.: To select a favorite song

- You can move to the other lists by pressing **◀◀/▶▶** (**▼/▲**).

■ Skipping channels

Once you skip channels, they can be selected neither using the **▲/▼** nor using the channel list.

While displaying the channel list (see page 42)...

Ex.: To skip the 3rd channel in the list.

1 Select a channel you want to skip.



2

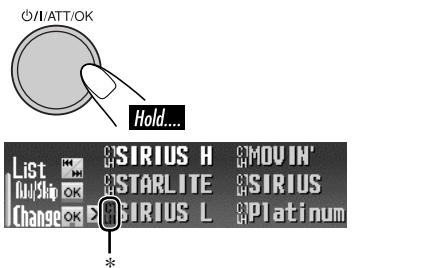

* The color of the channel indicator changes to gray when the channel is skipped.

- You can move to the other lists by pressing **◀◀/▶▶** (**▼/▲**).

3

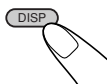

- The 3rd channel in the list is skipped.
- If you skip all channels in a category, the category itself will be skipped. (The color of the category indicator changes to gray.)

To add (restore) skipped channels, repeat the same procedure. (Select a skipped channel in step 1.)

- The color of the channel indicator is also restored.

To add (restore) skipped category, select "ALL" category (see step 3 on page 40), then add (restore) a skipped channel in the skipped category. (Skipped category will be restored automatically.)

- The color of the category indicator is also restored.

To change the display information

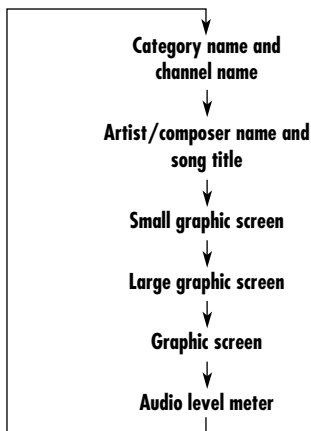
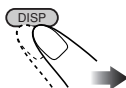

Maintenance

How to clean the connectors

Frequent detachment will deteriorate the connectors.

To minimize this possibility, periodically wipe the connectors with a cotton swab or cloth moistened with alcohol, being careful not to damage the connectors.

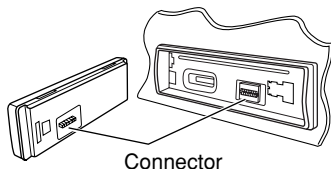

Moisture condensation

Moisture may condense on the lens inside the CD player in the following cases:

- After starting the heater in the car.
- If it becomes very humid inside the car.

Should this occur, the CD player may malfunction. In this case, eject the disc and leave the receiver turned on for a few hours until the moisture evaporates.

How to handle discs

When removing a disc from its case, press down the center holder of the case and lift the disc out, holding it by the edges.

Center holder



- Always hold the disc by the edges. Do not touch its recording surface.

When storing a disc into its case, gently insert the disc around the center holder (with the printed surface facing up).

- Make sure to store discs into the cases after use.

To keep discs clean

A dirty disc may not play correctly. If a disc does become dirty, wipe it with a soft cloth in a straight line from center to edge.



- Do not use any solvent (for example, conventional record cleaner, spray, thinner, benzene, etc.) to clean discs.

To play new discs

New discs may have some rough spots around the inner and outer edges. If such a disc is used, this receiver may reject the disc.



To remove these rough spots, rub the edges with a pencil or ball-point pen, etc.

How to handle SD card

SD cards are precision products. DO NOT impact, bend, drop, or wet them.

Available character

In addition to the Roman alphabets (A – Z, a – z), the following characters will be used.

- You can also use the following characters to assign titles (see page 36).

Accented letters: upper case

Á	À	Ã	Ä	Å	Æ	Œ	Č	Ć	Ç	É	È	Ê
Ë	Ĝ	Ĭ	Í	Ï	Ñ	Ó	Ô	Õ	Ö	Ø	Ř	
Š	Ś	Ş	Ú	Û	Ü	Ý	Ž	Ž	ß	Þ	Ɖ	
Ð	ƒ	Ł	ı	U	ø	space						

Accented letters: lower case

á	à	ã	ä	å	æ	œ	č	ć	ç	é	è	ê
ë	ĝ	ĭ	í	ï	ñ	ń	ó	ô	õ	ö		
š	ś	ş	ú	û	ü	ý	ž	ž	ß	þ	Ɖ	ŵ
ÿ	ÿ	ž	ž	ÿ	þ	ŋ	đ	ł	ı	ij	space	

Numbers and symbols

0	1	2	3	4	5	6	7	8	9	!	"	#	\$
%	&	'	()	*	+	,	-	.	/	:	;	<
=	>	?	@	_	`	ı	¿	£	€	α	space		

Do not use the following discs:

Warped disc



Sticker



Sticker residue

Disc



Stick-on label

More about this receiver

Basic operations

Turning on the power

- By pressing SOURCE on the receiver, you can also turn on the power.

Turning off the power

- If you turn off the power while listening to a disc, disc play will start from where playback has been stopped previously, next time you turn on the power.

Selecting the source

- When no disc or SD card is loaded in the receiver, “CD” or “SD” cannot be selected.
- Without connecting to the SIRIUS radio or CD changer, “SIRIUS” or “CD-CH” cannot be selected.
- To select the “EXT-IN” for the playback source, set the “Ext Input” setting correctly (see page 34).

Tuner operations

Storing stations in memory

- During SSM search...
 - All previously stored stations are erased and stations are stored newly.
 - Received stations are preset in No. 1 (lowest frequency) to No. 6 (highest frequency).
 - When SSM is over, the station stored in No. 1 will be automatically tuned in.
- When storing a station manually, a previously preset station is erased when a new station is stored in the same preset number.

Disc/SD card operations

Caution for DualDisc playback

- The Non-DVD side of a “DualDisc” does not comply with the “Compact Disc Digital Audio” standard. Therefore, the use of Non-DVD side of a DualDisc on this product may not be recommended.

General

- This receiver has been designed to reproduce CDs/CD Texts, and CD-Rs (Recordable)/CD-RWs (Rewritable) in audio CD (CD-DA), MP3 and WMA format and MP3/WMA files recorded in an SD card.
- When a disc or an SD card has been loaded, selecting “CD” or “SD” for the playback source starts playback.

Inserting a disc

- When a disc is inserted upside down, the control panel moves down, and the disc automatically ejects from the loading slot.
- If you keep the control panel open for about 1 minute, (beeps sound when the “Beep” setting is turned “On”—see page 34) the control panel returns to its previous position.

Playing a disc/SD card

- While playing an audio CD: If a title has been assigned to the audio CD (see page 36), it will be shown on the display.
- While fast-forwarding or reversing an MP3 or WMA track, you can only hear intermittent sounds.
- While playing an SD card, the playback order may differ from the one played back using other SD players.
- This receiver may be unable to play back some SD card due to their characteristics or recording conditions.
- This receiver cannot play back mini SD card and MMC.
- If the inserted SD card does not have the correct files, you cannot select “SD” for the playback source.

To be continued....

Playing a CD-R or CD-RW

- Use only “finalized” CD-Rs or CD-RWs.
- This receiver can play back only the files of the same type which is first detected if a disc includes both audio CD (CD-DA) files and MP3/WMA files.
- This receiver can play back multi-session discs; however, unclosed sessions will be skipped while playing.
- Some CD-Rs or CD-RWs may not play back on this receiver because of their disc characteristics, and for the following causes:
 - Discs are dirty or scratched.
 - Moisture condensation occurs on the lens inside the receiver.
 - The pickup lens inside the receiver is dirty.
 - CD-R/CD-RW on which the files are written with “Packet Write” method.
 - Improper recording conditions (missing data, etc.) or media conditions (stain, scratch, warp, etc.).
- CD-RWs may require a longer readout time since the reflectance of CD-RWs is lower than that of regular CDs.
- Do not use the following CD-Rs or CD-RWs:
 - Discs with stickers, labels, or protective seal stuck to the surface.
 - Discs on which labels can be directly printed by an ink jet printer.
 Using these discs under high temperatures or high humidities may cause malfunctions or damages to discs.

Playing an MP3/WMA track

- This receiver can play back MP3/WMA files with the extension code <.mp3> or <.wma> (regardless of the letter case—upper/lower).
- This receiver can show the names of albums, artists (performer), and ID3 Tag (Version 1.0, 1.1, 2.2, 2.3, or 2.4) for MP3 files and for WMA files.

- This receiver can display only one-byte characters. No other characters can be correctly displayed (see page 44).
- This receiver can play back MP3/WMA files meeting the conditions below:
 - Bit rate: 8 kbps — 320 kbps
 - Sampling frequency:
 - 48 kHz, 44.1 kHz, 32 kHz (for MPEG-1)
 - 24 kHz, 22.05 kHz, 16 kHz (for MPEG-2)
 - 48 kHz, 44.1 kHz, 32 kHz (for WMA)
 - Disc format: ISO 9660 Level 1/ Level 2, Romeo, Joliet, Windows long file name
- For MP3/WMA discs:
 - The maximum number of characters for file/folder names vary among the disc format used (includes 4 extension characters—<.mp3> or <.wma>).
 - ISO 9660 Level 1: up to 12 characters
 - ISO 9660 Level 2: up to 31 characters
 - Romeo*: up to 128 (72) characters
 - Joliet*: up to 64 (36) characters
 - Windows long file name*: up to 128 (72) characters
 - * *The parenthetic figure is the maximum number of characters for file/folder names in case the total number of files and folders is 313 or more.*
- For SD cards:
 - The maximum number of characters for folder name is 8 characters; file name is 12 characters.
 - The receiver cannot recognize folder with period (.) on the folder name.
- This receiver can recognize the total of 512 files, of 200 folders, and of 8 hierarchies of an MP3/WMA disc; 255 files and 63 folders of an SD card.
- This receiver can play back the files recorded in VBR (variable bit rate).
 - The files recorded in VBR have a discrepancy in elapsed time display, and do not show the actual elapsed time. Especially, after performing the search function, this difference becomes noticeable.

- This receiver cannot play back the following files:
 - MP3 files encoded with MP3i and MP3 PRO format.
 - MP3 files encoded in an unappropriated format.
 - MP3 files encoded with Layer 1/2.
 - WMA files encoded with lossless, professional, and voice format.
 - WMA files which are not based upon Windows Media® Audio.
 - WMA files copy-protected with DRM.
 - Files which have the data such as WAVE, ATAC3, etc.
- The search function works but search speed is not constant.

Changing the source

- If you change the source, playback also stops (without ejecting the disc).
Next time you select “CD,” “SD,” or “CD-CH” for the playback source, playback starts from where it has been stopped previously.

ImageLink

- “Large” ImageLink screen will be temporarily changed to source operation screen when you operate the receiver.
- ImageLink will not work in the following cases:
 - If no <jpw> file is included in an MP3/WMA folder.
 - If Intro Scan is activated.
 - If the source is changed to another from “CD” or “SD.”
- If more than one <jpw> file are included in a folder, a file with the youngest file number is used for the graphic screen.

Ejecting a disc

- If the ejected disc is not removed within 15 seconds, the disc is automatically inserted again into the loading slot to prevent it from dust. (Disc will not play this time.)

Sound adjustment

Selecting the DSP modes—DSP

- Effectiveness of “V.Cancel” depends on the recording condition of the sources. Especially, if you play back the following sources you cannot get the satisfactory results.
 - Monaural sources such as AM and monaural FM broadcasting programs,
 - Multiplex sound sources, and
 - Sources recorded with duets, strong echo, a chorus, or only a few instruments.
- If “V.Cancel” is selected, CCC, BBE, and preset sound modes (EQ) will not be adjusted (“Fix” appears on the display.)
- When “4ch” is selected, rear speakers are used only to reproduce reflections and reverberations in order to create a being-there feeling in your car compartment.
- If fader or balance has been set close to its extreme, appropriate effect may not be obtained.

Setting the basic sound selection menu

—SEL

- If you are using a two-speaker system, set the fader level to the center.
- Subwoofer out setting takes effect only when a subwoofer is connected.
- You cannot change the input level—“VolAdjust” of the FM stations. If the source is FM, “Fix” will appear when you try to adjust it.

Storing your own sound modes

- If you do not want to store your current adjustment, but only to apply the adjustment to the current playback source, press MENU to go back to the operation screen of the current source. Adjustment you made remains effective until you select a sound mode.

To be continued....

Graphic displays

General

- You can display two sizes of pictures and animations (see page 5).
 - Large: <jpl> for the still pictures and <jpa> for the animations;
The image can be shown as the display background.
 - Small: <jpm> for the still pictures and <jpb> for the animations;
The image is displayed like a CD jacket (in the same proportion of CD jacket).

Downloading (or deleting) files

- You can download a file only while selecting “CD” or “SD” for the playback source; on the other hand, you can delete a file while selecting any source.
- If you have already downloaded an animation, downloading a new animation deletes the previously stored animation.
- It takes a long time to download files.
 - About 6 seconds for a still image (one frame).
 - About 6 minutes for an animation of 60 frames.
- If a disc inserted does not include any <jpl>, <jpm>, <jpa>, and <jpb> files, beeps sound when you try to operate the downloading procedure.
- If you try to store the 16th image for picture screen for each “Large” and “Small” size, “Picture Full” appears and you cannot start downloading. Delete unwanted files before downloading.

General settings—PSM

- To set the “PICT” setting as you like, download the required files before setting. If “Default” (for “Picture” and “Movie”) and “No Slide” (for “Slideshow”) cannot be changed to other options, required files have not been downloaded.
- “Auto Dimmer” may not work correctly on some vehicles, particularly on those having a control dial for dimming. In this case, change the “Dimmer” setting to any one other than “Auto.”

- If you change the “Amp Gain” setting from “HighPower” to “Low Power” while the volume level is set higher than “30,” the receiver automatically changes the volume level to “30.”

SIRIUS® radio operations

General

- You can connect the JVC SIRIUS radio PnP (Plug and Play), KT-SR1000 or KT-SR2000, using the JVC SIRIUS radio adapter, KS-U100K (not supplied). By turning on the power to the receiver, you can turn on/off the JVC PnP. However, you cannot control it from this receiver.
- Signal strength bar increases as the receiving signal improves. If no signal is received, it disappears.
- When changing the category or channel, invalid and unsubscribed channels are skipped automatically.

Selecting a category/channel on the list

- If no operation is done within 15 seconds, the channel list disappears.
- Skipping channels:
 - You cannot skip CH184.
 - If all channels in a category are skipped, the category itself is also skipped.

Other main functions

Assigning titles to the sources

- If you try to assign a title to the 31st disc or a 31st station frequency, “Name Full” appears and you cannot enter the text entry mode. Delete unwanted titles before assignment.
- Titles assigned to discs in the CD changer can also be shown if you play back the disc in the receiver.

Troubleshooting

What appears to be trouble is not always serious. Check the following points before calling a service center.

	Symptoms	Causes	Remedies
General	<ul style="list-style-type: none"> • Sound cannot be heard from the speakers. 	The volume level is set to the minimum level. Connections are incorrect.	Adjust it to the optimum level. Check the cords and connections.
	<ul style="list-style-type: none"> • The receiver does not work at all. 	The built-in microcomputer may have functioned incorrectly due to noise, etc.	Reset the receiver (see page 2).
	<ul style="list-style-type: none"> • “Connect Error” appears on the display. 	The control panel is not attached correctly.	Remove the control panel, wipe the connector, then attach it again (see pages 37 and 44).
	<ul style="list-style-type: none"> • “Push Reset” appears on the display and the control panel movement is frozen. 	Something is blocking the control panel movement.	Reset the receiver (see page 2). If this does not work, check the installation.
FM/AM	<ul style="list-style-type: none"> • SSM automatic presetting does not work. 	Signals are too weak.	Store stations manually.
	<ul style="list-style-type: none"> • Static noise while listening to the radio. 	The antenna is not connected firmly.	Connect the antenna firmly.
Disc playback	<ul style="list-style-type: none"> • CD-R/CD-RW cannot be played back. • Tracks on the CD-R/CD-RW cannot be skipped. 	CD-R/CD-RW is not finalized.	<ul style="list-style-type: none"> • Insert a finalized CD-R/CD-RW. • Finalize the CD-R/CD-RW with the component which you used for recording.
	<ul style="list-style-type: none"> • Disc cannot be ejected. 	Disc is locked.	Unlock the disc (see page 19).
	<ul style="list-style-type: none"> • Disc cannot be recognized (“No Disc,” “Loading Error,” or “Eject Error” flashes). 	The CD player may have functioned incorrectly.	Eject the disc forcibly (see page 4).
	<ul style="list-style-type: none"> • Disc sound is sometimes interrupted. 	You are driving on rough roads.	Stop playback while driving on rough roads.
		Disc is scratched. Connections are incorrect.	Change the disc. Check the cords and connections.

To be continued....

	Symptoms	Causes	Remedies
MP3/WMA disc/SD card playback	<ul style="list-style-type: none"> • “No Files” appears for a while, then the disc ejects. 	No MP3/WMA tracks are recorded.	Change the disc or the SD card.
		MP3/WMA tracks do not have the extension code <.mp3> or <.wma> in their file names.	Add the extension code <.mp3> or <.wma> to their file names.
		MP3/WMA tracks are not recorded in the format compliant with ISO 9660 Level 1, Level 2, Romeo, or Joliet.	Change the disc or the SD card. (Record MP3/WMA tracks using a compliant application.)
	<ul style="list-style-type: none"> • Noise is generated. 	The track played back is not an MP3/WMA track (although it has the extension code <.mp3> or <.wma>).	Skip to another track or change the disc or the SD card. (Do not add the extension code <.mp3> or <.wma> to non-MP3 or WMA tracks.)
	<ul style="list-style-type: none"> • Elapsed playing time is not correct. 	This sometimes occurs during play. This is caused by how the tracks are recorded.	_____
	<ul style="list-style-type: none"> • “Not Support” appears on the display and track skips. 	<ul style="list-style-type: none"> • Tracks are not encoded in an appropriate format. • Copy-protected WMA tracks cannot be played back. 	Skip to the next track.
	<ul style="list-style-type: none"> • “No Music” appears on the display. 	<ul style="list-style-type: none"> • No MP3/WMA tracks are recorded on the disc. • Only <.jpl>, <.jpm>, <.jpa>, <.jpb>, <.jpw> files are recorded on the disc. 	Change the disc or the SD card (formatted in FAT 12/16).
	<ul style="list-style-type: none"> • “SD Loading Error” appears on the display. 	SD card is not inserted correctly.	Detach the control panel and reinsert the SD card. The control panel goes back to initial position (Angle 1): see page 37.
	<ul style="list-style-type: none"> • “Read Failed” appears on the display. 	Tracks are not encoded in an appropriate format.	Use SD card formatted in FAT 12/16.
		The SD card or tracks cannot be played back.	Change the SD card.
<ul style="list-style-type: none"> • Correct characters are not displayed (ex. album name). 	This receiver can only display a limited number of special characters (see page 44).	_____	

	Symptoms	Causes	Remedies
Sounds	<ul style="list-style-type: none"> • CCC, BBE, and preset sound modes (EQ) cannot be used. 	These sound adjustments cannot be performed when “V.Cancel” is selected for the DSP mode.	Select any mode other than “V.Cancel” for the DSP mode.
Graphics	<ul style="list-style-type: none"> • Download does not seem to finish. 	It takes quite a long time to download an animation of many frames (see page 48).	_____
PICT—PSM	<ul style="list-style-type: none"> • The display graphic function does not work correctly. 	Temperature in the car compartment is very low.	Wait until the operating temperature resumes.
	<ul style="list-style-type: none"> • You cannot activate “Slideshow” for “PICT” (“No Slide” is shown as the selectable item). 	No still images are downloaded yet.	Download a still image.
CD changer	<ul style="list-style-type: none"> • “No Magazine” flashes on the display. 	No magazine is loaded in the CD changer.	Insert the magazine.
	<ul style="list-style-type: none"> • “No Disc” flashes on the display. 	No disc is in the magazine.	Insert disc into the magazine.
		Disc is inserted upside down.	Insert disc correctly.
	<ul style="list-style-type: none"> • “Reset 08” flashes on the display. 	This receiver is not connected to the CD changer correctly.	Connect this receiver and the CD changer correctly and press the reset button of the CD changer.
	<ul style="list-style-type: none"> • “Reset 01” – “Reset 07” flashes on the display. 	The CD player may have functioned incorrectly.	Press the reset button of the CD changer.
<ul style="list-style-type: none"> • The CD changer does not work at all. 	The built-in microcomputer may function incorrectly due to noise, etc.	Reset the receiver (see page 2).	

To be continued....

	Symptoms	Causes	Remedies
SIRIUS	• “CALL 1-888-539-SIRIUS TO SUBSCRIBE” scrolls on the display.	Subscription has not been done.	Starts subscribing (see page 39).
	• “No Signal” appears on the display	Signals are too weak.	Move to an area with stronger signals.
	• “No Antenna” appears on the display.	The antenna is not connected firmly.	Connect the antenna firmly.
	• “Invalid Channel” appears on the display for about 5 seconds, then returns to the previous display.	No broadcast on the selected channel.	Select another channel.
	• “Skipped Channel” appears when presetting a channel.	The channel is set to be skipped.	Add the channel again (see page 43).
	• You cannot select a certain category.	All channels in the category are skipped.	Restoring a skipped channel automatically restore the category.
	• “No name” appears on the display.	No text information for the selected channel.	_____
	• No sound can be heard.	“Channels Updating XX%* Completed” appears on the display.	The receiver is updating the channel information and it takes a few minutes to complete.
	• SIRIUS radio does not work at all.	The built-in microcomputer may function incorrectly due to noise, etc.	Reconnect the SIRIUS radio after a few seconds.
	• “Reset 08” flashes on the display.	Connections are incorrect.	Check the cords and connections.

* Changes every 20% of update until completed (ex. 20%, 40%, 60%).

- Microsoft and Windows Media are either registered trademarks or trademarks of Microsoft Corporation in the United States and/or other countries.
- SD logo is a trademark.

Specifications

AUDIO AMPLIFIER SECTION

Power Output:

22 W RMS \times 4 Channels at 4 Ω
and \leq 1% THD+N

Signal-to-Noise Ratio:

80 dBA (reference: 1 W into 4 Ω)



Load Impedance: 4 Ω (4 Ω to 8 Ω allowance)

Equalizer Control Range:

Frequencies: 60 Hz, 150 Hz, 400 Hz,
1 kHz, 2.4 kHz, 6 kHz,
12 kHz

Level: \pm 10 dB

Frequency Response: 40 Hz to 20 000 Hz

Line-In Level/Impedance:

LINE IN: 1.5 V/20 k Ω load

Line-Out Level/Impedance:

LINE OUT: 5.0 V/20 k Ω load (full scale)

Output Impedance: 1 k Ω

Other Terminals:

SUBWOOFER OUT

Changer control

Steering wheel remote input

TUNER SECTION

Frequency Range:

FM: 87.5 MHz to 107.9 MHz
(with channel interval set to 200 kHz)

87.5 MHz to 108.0 MHz
(with channel interval set to 50 kHz)

AM: 530 kHz to 1 710 kHz
(with channel interval set to 10 kHz)
531 kHz to 1 602 kHz
(with channel interval set to 9 kHz)

[FM Tuner]

Usable Sensitivity: 11.3 dBf (1.0 μ V/75 Ω)

50 dB Quietening Sensitivity: 16.3 dBf (1.8 μ V/75 Ω)

Alternate Channel Selectivity (400 kHz): 65 dB

Frequency Response: 40 Hz to 15 000 Hz

Stereo Separation: 35 dB

Capture Ratio: 1.5 dB

[AM Tuner]

Sensitivity: 20 μ V

Selectivity: 65 dB

CD/SD PLAYER SECTION

Type: Compact disc player

Signal Detection System: Non-contact optical pickup (semiconductor laser)

Number of Channels: 2 channels (stereo)

Frequency Response: 5 Hz to 20 000 Hz

Dynamic Range: 98 dB

Signal-to-Noise Ratio: 102 dB

Wow and Flutter: Less than measurable limit

MP3 (MPEG Audio Layer 3):

Max. Bit Rate: 320 kbps

WMA (Windows Media[®] Audio):

Max. Bit Rate: 192 kbps

Playable SD Card: Format: FAT 12/16

Storage: Up to 512 MB

Playable Audio Format for SD Card:

MP3/WMA

GENERAL

Power Requirement:

Operating Voltage:

DC 14.4 V (11 V to 16 V allowance)

Grounding System: Negative ground

Allowable Operating Temperature:

0°C to +40°C (32°F to 104°F)

Dimensions (W \times H \times D):

Installation Size (approx.):

182 mm \times 52 mm \times 157 mm
(7-3/16" \times 2-1/16" \times 6-3/16")

Panel Size (approx.):

188 mm \times 58 mm \times 13 mm
(7-7/16" \times 2-5/16" \times 9/16")

Mass (approx.):

1.7 kg (3.8 lbs) (excluding accessories)

Design and specifications are subject to change without notice.

If a kit is necessary for your car, consult your telephone directory for the nearest car audio speciality shop.



Having TROUBLE with operation?

Please reset your unit

Refer to page of How to reset your unit

Still having trouble??

USA ONLY

Call 1-800-252-5722

<http://www.jvc.com>

We can help you!

JVC



EN, SP, FR

© 2005 Victor Company of Japan, Limited

0205MNMDWJEIN

JVC KD-AR7500/KD-SHX750

Installation/Connection Manual Manual de instalación/conexión Manuel d'installation/raccordement

LVT1310-002A
[J]

0205MNMMDWJEIN
EN, SP, FR

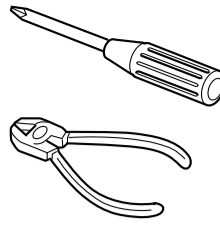

ENGLISH

ESPAÑOL

FRANÇAIS

This receiver is designed to operate on **12 V DC, NEGATIVE ground electrical systems**. If your vehicle does not have this system, a voltage inverter is required, which can be purchased at JVC car audio dealers.

Esta unidad está diseñada para funcionar con **12 V de CC, con sistemas eléctricos de masa NEGATIVA**. Si su vehículo no posee este sistema, será necesario un inversor de tensión, que puede ser adquirido en los concesionarios de JVC de equipos de audio para automóviles.

Cet appareil est conçu pour fonctionner sur des sources de courant continu de **12 V à masse NEGATIVE**. Si votre véhicule n'offre pas ce type d'alimentation, il vous faut un convertisseur de tension, que vous pouvez acheter chez un revendeur d'autoradios JVC.

Parts list for installation and connection







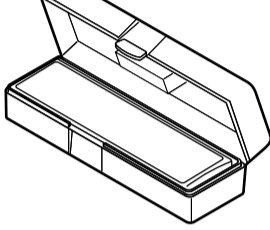
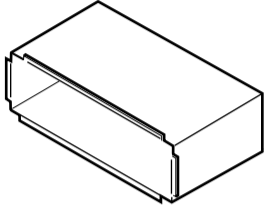
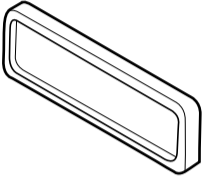
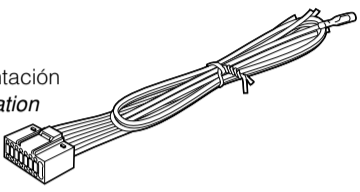

The following parts are provided for this receiver. After checking them, please set them correctly.

Lista de piezas para instalación y conexión

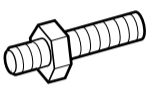
Con esta unidad se suministran las siguientes piezas. Después de inspeccionarlas, colóquelas correctamente.

Liste des pièces pour l'installation et raccordement

Les pièces suivantes sont fournies avec cet appareil. Après vérification, veuillez les placer correctement.

<p>(A) / (B) Hard case/Control panel Estuche duro/Panel de control Etui de transport/ Panneau de commande</p> 	<p>(C) Sleeve Cubierta Manchon</p> 	<p>(D) Trim plate Placa de guarnición Plaque d'assemblage</p> 	<p>(E) Power cord Cordón de alimentación Cordon d'alimentation</p> 
<p>(F) Washer (ø5) Arandela (ø5) Rondelle (ø5)</p> 	<p>(G) Lock nut (M5) Tuerca de seguridad (M5) Ecrou d'arrêt (M5)</p> 	<p>(H) Mounting bolt— M5 x 20 mm (M5 x 13/16") Perno de montaje— M5 x 20 mm (M5 x 13/16 pulgada) Boulon de montage— M5 x 20 mm (M5 x 13/16 pouces)</p> 	<p>(I) Rubber cushion Cojín de goma Amortisseur en caoutchouc</p> 
<p>(J) Handles Manijas Poignées</p> 	<p>(K) Remote controller Control remoto Télécommande</p>  <p>RM-RK300</p>	<p>(L) Battery Pila Pile</p>  <p>CR2025</p>	<p>(M) CD-ROM (Image Converter: Color Ver. 2.0) CD-ROM (Image Converter: Color Ver. 2.0) CD-ROM (Image Converter: Color Ver. 2.0)</p> 

Only for KD-AR7500 / Solo para KD-AR7500 /
Seulement pour le KD-AR7500

- Refer to "USB READER/WRIter" user's guide for more details.
- Para más detalles, consulte la guía del usuario del "LECTOR/ ESCRITOR USB".
- Pour plus de détails, référez-vous au guide d'utilisation du "LECTEUR/ENREGISTREUR USB".

(N)
USB reader/writer
Lector/escritor USB
Lecteur/enregistreur USB

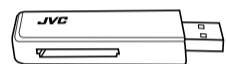

KS-USB10

(O)
USB cable
Cable USB
Câble USB

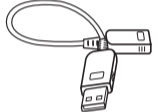

(P)
SD memory card (8 MB)
Tarjeta de memoria SD (8 MB)
Carte mémoire SD (8 Mo)



INSTALLATION (IN-DASH MOUNTING)

INSTALACION (MONTAJE EN EL TABLERO DE INSTRUMENTOS)

INSTALLATION (MONTAGE DANS LE TABLEAU DE BORD)

The following illustration shows a typical installation. If you have any questions or require information regarding installation kits, consult your JVC car audio dealer or a company supplying kits.

- If you are not sure how to install this receiver correctly, have it installed by a qualified technician.

La siguiente ilustración muestra una instalación típica. Si tiene alguna pregunta o necesita información acerca de las herramientas para instalación, consulte con su concesionario de JVC de equipos de audio para automóviles o a una compañía que suministra tales herramientas.

- Si usted no está seguro de cómo instalar correctamente la unidad, hágala instalar por un técnico cualificado.

L'illustration suivante est un exemple d'installation typique. Si vous avez des questions ou avez besoin d'information sur des kits d'installation, consulter votre revendeur d'autoradios JVC ou une compagnie d'approvisionnement.

- Si l'on n'est pas sûr de pouvoir installer correctement cet appareil, le faire installer par un technicien qualifié.

1

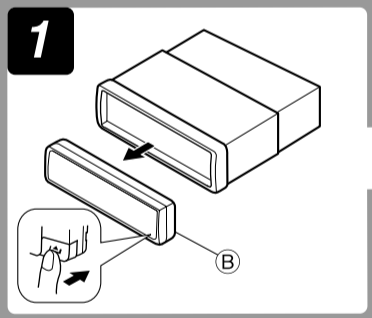

2

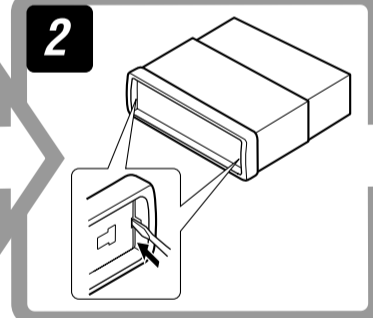

3

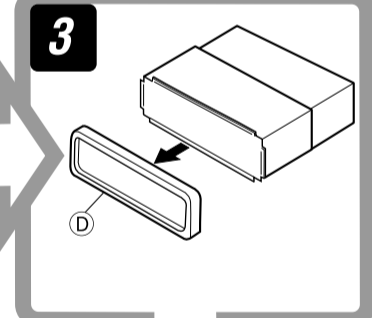

4

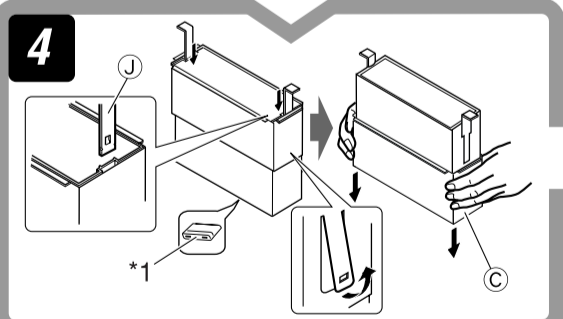

5

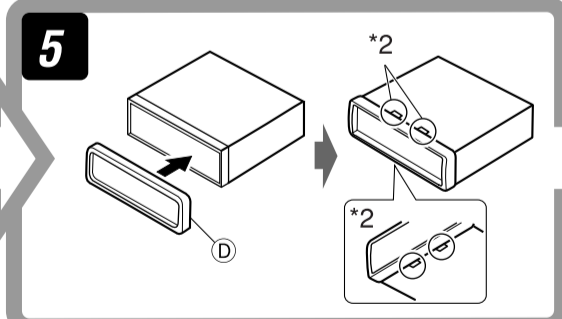

6

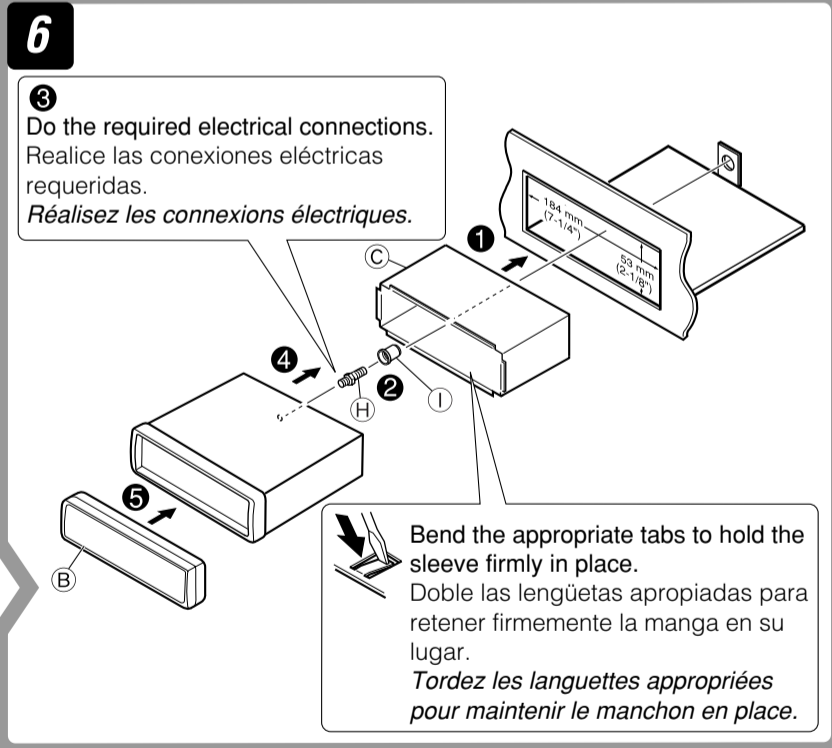

③ Do the required electrical connections. Realice las conexiones eléctricas requeridas. Réalisez les connexions électriques.

Bend the appropriate tabs to hold the sleeve firmly in place. Doble las lengüetas apropiadas para retener firmemente la manga en su lugar. Tordez les languettes appropriées pour maintenir le manchon en place.

*1 When you stand the receiver, be careful not to damage the fuse on the rear.

*1 Al poner la unidad vertical, tenga cuidado de no dañar el fusible provisto en la parte posterior.

*1 Lorsque vous mettez l'appareil à la verticale, faire attention de ne pas endommager le fusible situé sur l'arrière.

*2 Fit the protrusions outside the receiver.

*2 Haga encajar los salientes del exterior de la unidad.

*2 Fixez les protubérances à l'extérieur de l'appareil.

Removing the receiver

Before removing the receiver, release the rear section.

Extracción de la unidad

Antes de extraer la unidad, libere la sección trasera.

Retrait de l'appareil

Avant de retirer l'appareil, libérer la section arrière.

1

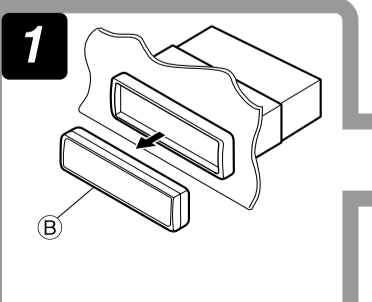

2

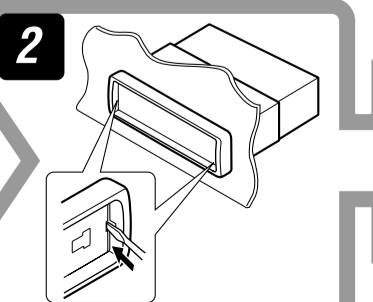

3

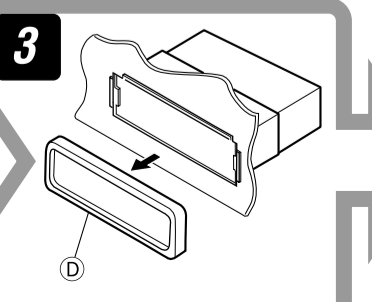

4

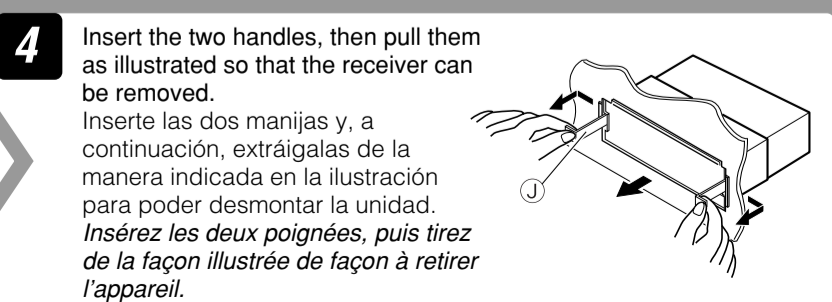

Insert the two handles, then pull them as illustrated so that the receiver can be removed. Insérez les deux poignées, puis tirez de la façon illustrée de façon à retirer l'appareil.

When using the optional stay / Cuando emplea un soporte opcional / Lors de l'utilisation du hauban en option

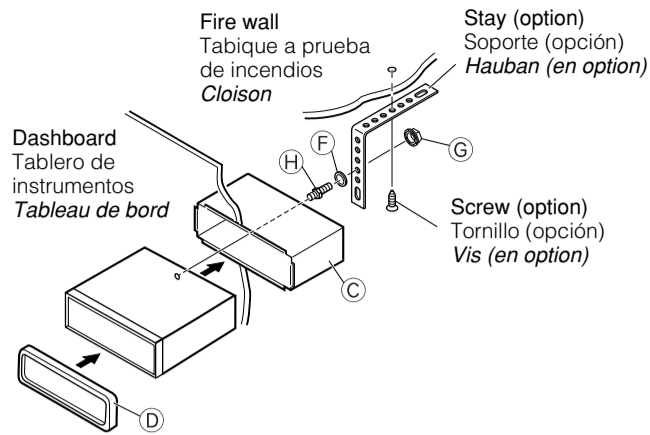

Install the receiver at an angle of less than 30°. Instale la unidad a un ángulo de menos de 30°. Installez l'appareil avec un angle de moins de 30°.

When installing the receiver without using the sleeve / Instalación de la unidad sin utilizar la cubierta / Lors de l'installation de l'appareil sans utiliser de manchon

In a Toyota for example, first remove the car radio and install the receiver in its place. En un Toyota por ejemplo, primero retire la radio del automóvil y luego instale la unidad en su lugar. Par exemple dans une Toyota, retirer d'abord l'autoradio et installer l'appareil à la place.

Flat type screws—M5 x 8 mm (M5 x 3/8") *3
Tornillos tipo plano—M5 x 8 mm (M5 x 3/8 pulgada) *3
Vis à tête plate—M5 x 8 mm (M5 x 3/8 pouces) *3

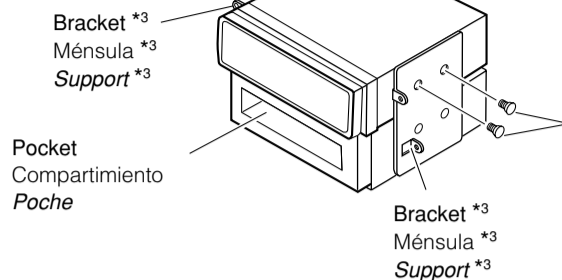

*3 Not included for this receiver. *3 No suministrado con esta unidad. *3 Non fourni avec cet appareil.

- Note :** When installing the receiver on the mounting bracket, make sure to use the 8 mm (3/8")-long screws. If longer screws are used, they could damage the receiver.
- Nota :** Cuando instala la unidad en la ménsula de montaje, asegúrese de utilizar los tornillos de 8 mm (3/8 pulgada) de longitud. Si se utilizan tornillos más largos, éstos pueden dañar la unidad.
- Remarque :** Lors de l'installation de l'appareil sur le support de montage, s'assurer d'utiliser des vis d'une longueur de 8 mm (3/8 pouces). Si des vis plus longues sont utilisées, elles peuvent endommager l'appareil.

Caution when installing / Precaución en la instalación / Précautions lors de l'installation:

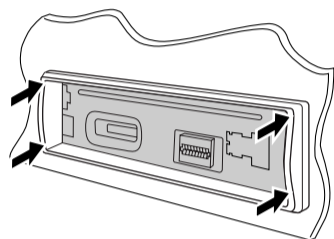

- Fit the receiver into the mounting sleeve by using four corners of the trim plate.
- DO NOT press the panel (shaded in the illustration).
 - Introduzca el receptor en la manga de montaje utilizando las cuatro esquinas de la placa decorativa.
 - NO presione el panel (sombreado en la ilustración).
- Fixez l'autoradio sur le manchon de montage en utilisant les quatre coins de la plaque de garniture.
- NE PUSSEZ PAS sur le panneau (en gris sur l'illustration).

ELECTRICAL CONNECTIONS

To prevent short circuits, we recommend that you disconnect the battery's negative terminal and make all electrical connections before installing the receiver.

- Be sure to ground this receiver to the car's chassis again after installation.

Notes:

- Replace the fuse with one of the specified rating. If the fuse blows frequently, consult your JVC car audio dealer.
- It is recommended to connect to the speakers with maximum power of more than 52 W (both at the rear and at the front, with an impedance of 4 Ω to 8 Ω). If the maximum power is less than 52 W, change "Amp Gain" setting to prevent the speakers from being damaged (see page 34 of the INSTRUCTIONS).
- To prevent short-circuit, cover the terminals of the UNUSED leads with insulating tape.
- The heat sink becomes very hot after use. Be careful not to touch it when removing this receiver.

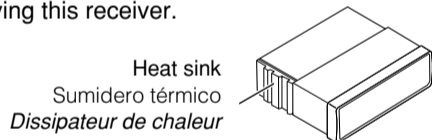

CONEXIONES ELECTRICAS

Para evitar cortocircuitos, recomendamos que desconecte el terminal negativo de la batería y que efectúe todas las conexiones eléctricas antes de instalar la unidad.

- Asegúrese de volver a conectar a masa esta unidad al chasis del automóvil después de la instalación.

Notas:

- Reemplace el fusible por uno con la corriente especificada. Si el fusible se quemase frecuentemente consulte con su concesionario de JVC de equipos de audio para automóviles.
- Se recomienda conectar los altavoces con una potencia máxima de más de 52 W (tanto atrás como adelante, con una impedancia de 4 Ω a 8 Ω). Si la potencia máxima es de menos de 52 W, cambie "Amp Gain" para evitar daños en los altavoces (consulte la página 34 del MANUAL DE INSTRUCCIONES).
- Para evitar cortocircuitos, cubra los cables NO UTILIZADOS con cinta aislante.
- El sumidero térmico estará muy caliente después del uso. Asegúrese de no tocarlo al desmontar esta unidad.

RACCORDEMENTS ELECTRIQUES

Pour éviter tout court-circuit, nous vous recommandons de débrancher la borne négative de la batterie et d'effectuer tous les raccordements électriques avant d'installer l'appareil.

- Assurez-vous de raccorder de nouveau la mise à la masse de cet appareil au châssis de la voiture après l'installation.

Remarques:

- Remplacer le fusible par un de la valeur précisée. Si le fusible saute souvent, consulter votre revendeur d'autoradios JVC.
- Il est recommandé de connecter des enceintes avec une puissance de plus de 52 W (les enceintes arrière et les enceintes avant, avec une impédance comprise entre 4 Ω et 8 Ω). Si la puissance maximum est inférieure à 52 W, changez "Amp Gain" pour éviter d'endommager vos enceintes (voir page 34 du MANUEL D'INSTRUCTIONS).
- Pour éviter les court-circuits, couvrir les bornes des fils qui ne sont PAS UTILISÉS avec de la bande isolante.
- Le dissipateur de chaleur devient très chaud après usage. Faire attention de ne pas le toucher en retirant cet appareil.

PRECAUTIONS on power supply and speaker connections:

- DO NOT connect the speaker leads of the power cord to the car battery; otherwise, the receiver will be seriously damaged.
- BEFORE connecting the speaker leads of the power cord to the speakers, check the speaker wiring in your car.

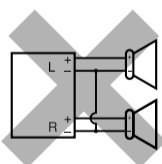

PRECAUCIONES sobre las conexiones de la fuente de alimentación y de los altavoces:

- NO conecte los conductores de altavoz del cable de alimentación a la batería de automóvil, pues podrían producirse graves daños en la unidad.
- ANTES de conectar a los altavoces los conductores de altavoz del cable de alimentación, verifique el conexionado de altavoz de su automóvil.

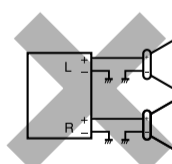

PRECAUTIONS sur l'alimentation et la connexion des enceintes:

- NE CONNECTEZ PAS les fils d'enceintes du cordon d'alimentation à la batterie; sinon, l'appareil serait sérieusement endommagé.
- AVANT de connecter les fils d'enceintes du cordon d'alimentation aux enceintes, vérifiez le câblage des enceintes de votre voiture.

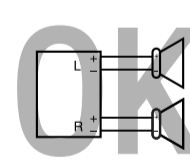

TROUBLESHOOTING

- **The fuse blows.**
 - * Are the red and black leads connected correctly?
- **Power cannot be turned on.**
 - * Is the yellow lead connected?
- **No sound from the speakers.**
 - * Is the speaker output lead short-circuited?
- **Sound is distorted.**
 - * Is the speaker output lead grounded?
 - * Are the "-" terminals of L and R speakers grounded in common?
- **Noise interfere with sounds.**
 - * Is the rear ground terminal connected to the car's chassis using shorter and thicker cords?
- **This receiver becomes hot.**
 - * Is the speaker output lead grounded?
 - * Are the "-" terminals of L and R speakers grounded in common?
- **This receiver does not work at all.**
 - * Have you reset your receiver?

LOCALIZACION DE AVERIAS

- **El fusible se quema.**
 - * ¿Están los conductores rojo y negro correctamente conectados?
- **No es posible conectar la alimentación.**
 - * ¿Está el cable amarillo conectado?
- **No sale sonido de los altavoces.**
 - * ¿Está el cable de salida del altavoz cortocircuitado?
- **El sonido presenta distorsión.**
 - * ¿Está el cable de salida del altavoz conectado a masa?
 - * ¿Están los terminales "-" de los altavoces L y R conectados a una masa común?
- **Perturbación de ruido.**
 - * ¿El terminal de tierra trasero está conectado al chasis del automóvil utilizando los cordones más corto y más grueso?
- **La unidad se calienta.**
 - * ¿Está el cable de salida del altavoz conectado a masa?
 - * ¿Están los terminales "-" de los altavoces L y R conectados a una masa común?
- **Este receptor no funciona en absoluto.**
 - * ¿Reinicializó el receptor?

EN CAS DE DIFFICULTES

- **Le fusible saute.**
 - * Les fils rouge et noir sont-ils raccordés correctement?
- **L'appareil ne peut pas être mise sous tension.**
 - * Le fil jaune est-elle raccordée?
- **Pas de son des enceintes.**
 - * Le fil de sortie d'enceinte est-il court-circuité?
- **Le son est déformé.**
 - * Le fil de sortie d'enceinte est-il à la masse?
 - * Les bornes "-" des enceintes gauche et droit sont-elles mises ensemble à la masse?
- **Intérférence avec les sons.**
 - * La prise arrière de mise à la terre est-elle connectée au châssis de la voiture avec un cordon court et épais?
- **L'appareil devient chaud.**
 - * Le fil de sortie d'enceinte est-il à la masse?
 - * Les bornes "-" des enceintes gauche et droit sont-elles mises ensemble à la masse?
- **Cet appareil ne fonctionne pas du tout.**
 - * Avez-vous réinitialisé votre appareil?

A Typical Connections / Conexiones típicas / Raccordements typiques

Before connecting: Check the wiring in the vehicle carefully. Incorrect connection may cause serious damage to this receiver.
The leads of the power cord and those of the connector from the car body may be different in color.

- 1 Connect the colored leads of the power cord in the order specified in the illustration below.
- 2 Connect the antenna cord.
- 3 Finally connect the wiring harness to the receiver.

Antes de la conexión: Verifique atentamente el conexionado del vehículo. Una conexión incorrecta podría producir daños graves en la unidad.
Los cordones del cable de alimentación y los del conector procedentes de la carrocería del automóvil podrían ser de diferentes en color.

- 1 Conecte los conductores de color del cable de alimentación en el orden especificado en la ilustración de abajo.
- 2 Conecte el cable de antena.
- 3 Por último, conecte el cable de alimentación a la unidad.

Avant de commencer la connexion: Vérifiez attentivement le câblage du véhicule. Une connexion incorrecte peut endommager sérieusement l'appareil.
Le fil du cordon d'alimentation et ceux des connecteurs du châssis de la voiture peuvent être différents en couleur.

- 1 Connectez les fils colorés du cordon d'alimentation dans l'ordre spécifié sur l'illustration ci-dessous.
- 2 Connectez le cordon d'antenne.
- 3 Finalement, connectez le faisceau de fils à l'appareil.

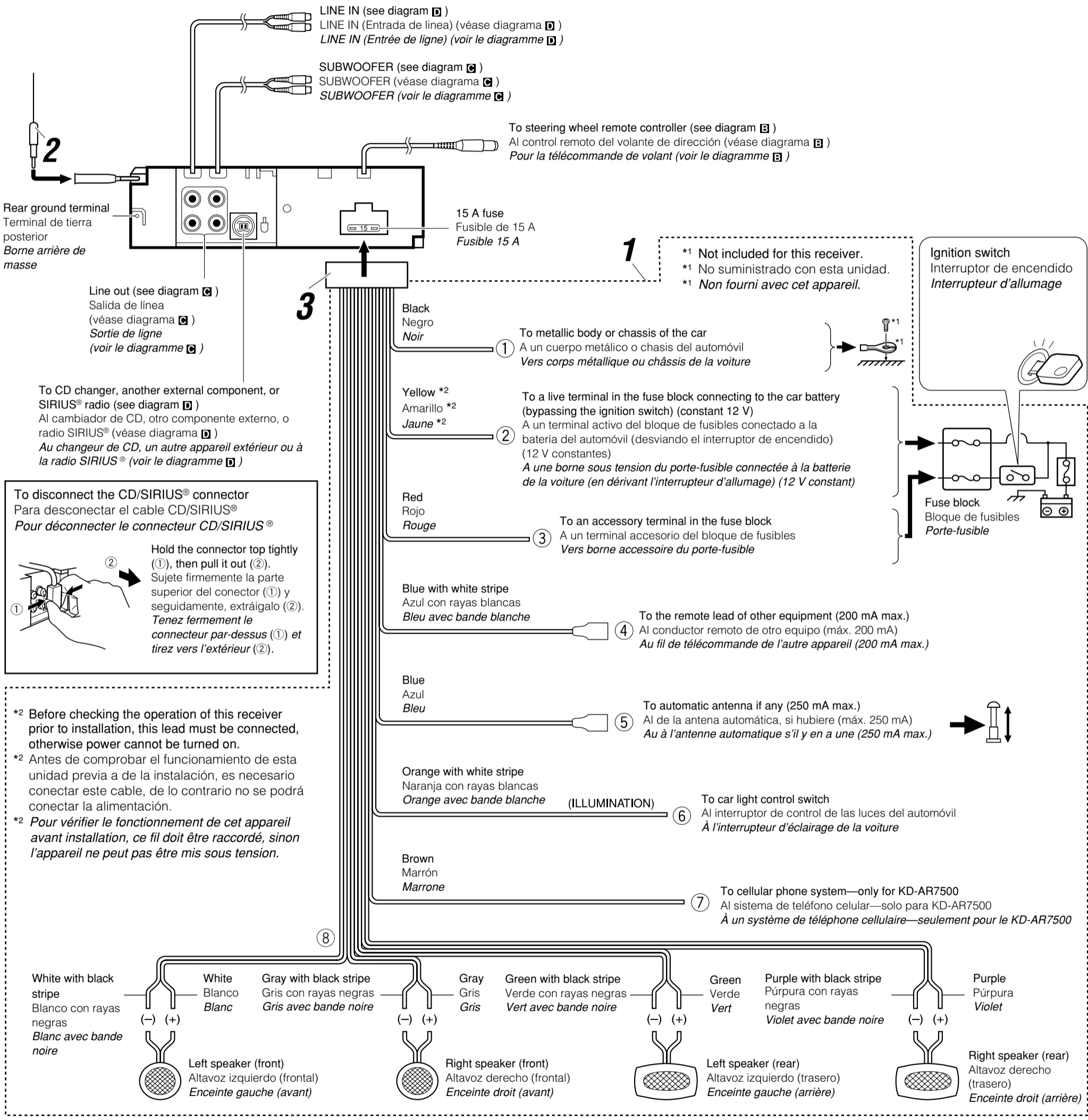

B Connecting to the steering wheel remote controller / Conexión al control remoto del volante de dirección / Connexion de la télécommande de volant

If your car is equipped with the steering wheel remote controller, you can operate this receiver using the controller. For connection, an exclusive remote adapter (not supplied) which matches your car is required. For details, consult the same car audio dealer as where the receiver is purchased.
Si su vehículo está equipado con control remoto en el volante de dirección, podrá controlar este receptor utilizando dicho control. Para la conexión, necesitará un adaptador remoto exclusivo (no suministrado) que corresponda con su vehículo. Para los detalles, consulte con el concesionario car audio donde compró el receptor.
Si votre voiture est munie d'une télécommande de volant, vous pouvez commander cet autoradio en utilisant cette télécommande. Pour la connexion, vous devez utiliser un adaptateur de télécommande spécialisé (non fourni) correspondant à votre voiture. Pour les détails, consultez le revendeur d'autoradio où vous avez acheté cet appareil.

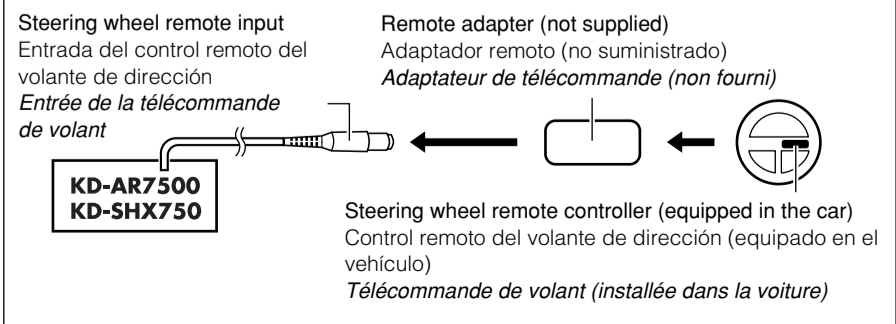

C Connecting the external amplifiers / Conexión a los amplificadores externos / Connexion d'amplificateurs extérieurs

You can connect amplifiers to upgrade your car stereo system.

- Connect the remote lead (blue with white stripe) to the remote lead of the other equipment so that it can be controlled through this receiver.
- **For amplifier only:**
 - Disconnect the speakers from this receiver, connect them to the amplifier. Leave the speaker leads of this receiver unused.
 - You can switch off the built-in amplifier and send the audio signals only to the external amplifier(s) to get clear sounds and to prevent internal heat built-up inside the receiver (see page 34 of the INSTRUCTIONS).
 - The line output level of this receiver is kept high to maintain the hi-fi sounds reproduced from this receiver. When connecting an external amplifier to this receiver, turn down the gain control on the external amplifier to obtain the best performance from this receiver.

Usted podrá conectar amplificadores para mejorar el sistema estéreo de su automóvil.

- Conecte el conductor remoto (azul con rayas blancas) al conductor remoto del otro equipo para poderlo controlar a través de esta unidad.
- **Sólo para el amplificador:**
 - Desconecte los altavoces de esta unidad y conéctelos al amplificador. Los cables de los altavoces de esta unidad quedan sin usar.
 - Podrá desconectar el amplificador incorporado y enviar las señales de audio solamente al(los) amplificador(es) externo(s) para obtener sonidos nítidos y evitar que se caliente el interior de la unidad (consulte la página 34 del MANUAL DE INSTRUCCIONES).
 - El nivel de salida de línea de esta unidad permanece alto para que corresponda con los sonidos de alta fidelidad reproducidos por esta unidad. Cuando conecte un amplificador externo a esta unidad, disminuya el control de ganancia del amplificador externo para obtener un óptimo rendimiento de esta unidad.

Vous pouvez connecter des amplificateurs pour améliorer votre système autoradio.

- Connectez le fil de commande à distance (bleu avec bande blanche) au fil de commande à distance de l'autre appareil de façon qu'il puisse être commandé via cet appareil.
- **Pour l'amplificateur seulement:**
 - Déconnectez les enceintes de cet appareil et connectez-les à l'amplificateur. Laissez les fils d'enceintes de cet appareil inutilisés.
 - Vous pouvez désactiver l'amplificateur intégré et envoyer les signaux audio uniquement à un ou plusieurs amplificateurs extérieurs afin d'obtenir un son clair et pour éviter un échauffement interne de l'appareil (voir page 34 du MANUEL D'INSTRUCTIONS).
 - Le niveau de sortie de ligne de cet appareil est maintenu à un niveau élevé pour maintenir une qualité Hi-Fi pour les sons reproduits par cet appareil. Lors de la connexion d'un amplificateur extérieur à cet appareil, diminuez le réglage du gain sur l'amplificateur extérieur pour obtenir les meilleures performances de cet appareil.

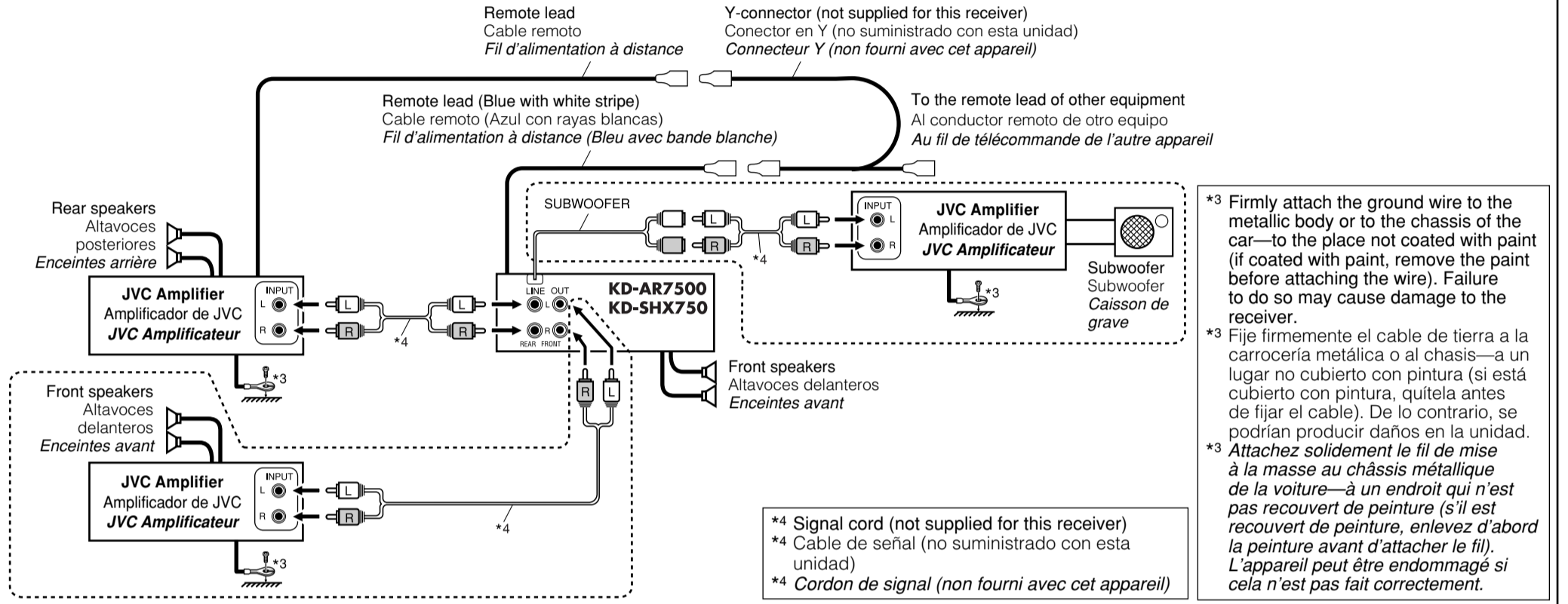

D Connecting the external components / Conexión a los componentes externos / Connexion d'un autre appareil extérieur

JVC CD changer and DLP (Down Link Processor) / Cambiador de CD de JVC y DLP ("Down Link Processor") JVC / Changeur de CD JVC et Processeur DLP (Processeur de signaux satellite-terre) JVC

- Set "Ext Input" to "Changer" (see page 34 of the INSTRUCTIONS). / Ajuste "Ext Input" a "Changer" (consulte la página 34 del MANUAL DE INSTRUCCIONES). / Réglez "Ext Input" sur "Changer" (voir la page 34 du MANUEL D'INSTRUCTIONS).
- You can connect both components in series as illustrated below.
- Podrá conectar ambos componentes en serie, tal como se observa en la ilustración de abajo.
- Vous pouvez connecter les deux appareils en série comme montré sur l'illustration.

CAUTION / PRECAUCION / PRECAUTION:

- Before connecting the CD changer and/or JVC DLP, make sure that the receiver is turned off.
- Antes de conectar el cambiador de CD y/o DLP JVC, asegúrese de que el receptor esté apagado.
- Avant de connecter votre changeur de CD et/ou votre processeur DLP JVC, assurez-vous que l'autoradio est hors tension.

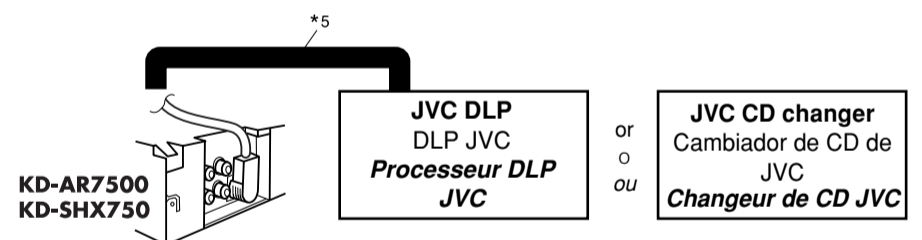
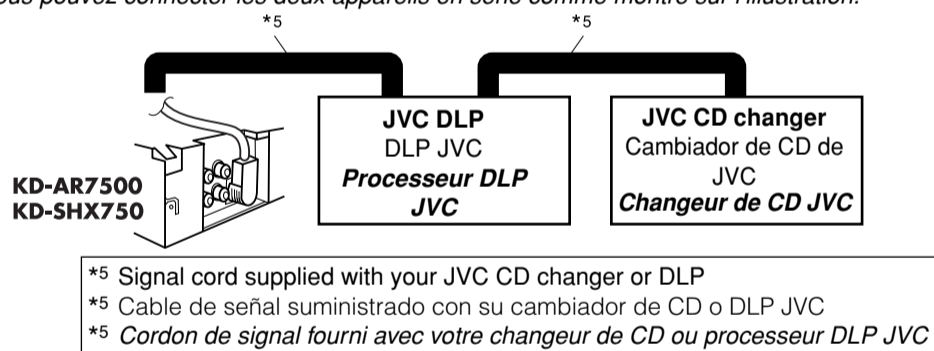

JVC PnP (Plug and Play) / PnP ("Plug and Play") JVC / PnP ("Plug and Play") JVC

- Set "Ext Input" to "Ext Input" (see page 34 of the INSTRUCTIONS). / Ajuste "Ext Input" a "Ext Input" (consulte la página 34 del MANUAL DE INSTRUCCIONES). / Réglez "Ext Input" sur "Ext Input" (voir la page 34 du MANUEL D'INSTRUCTIONS).

You can also connect JVC PnP through this receiver using JVC SIRIUS radio adapter, KS-U100K (optionally purchased).

- Turning on/off the receiver can also turns on/off the JVC PnP.
- También podrá conectar la PnP JVC a través de este receptor utilizando el adaptador para radio SIRIUS JVC, KS-U100K (adquirido opcionalmente).
- Al encender/apagar el receptor también se enciende/apaga la PnP JVC.
- Vous pouvez aussi connecter le PnP JVC à cet autoradio en utilisant l'adaptateur de radio SIRIUS JVC KS-U100K (vendu séparément).
- Mettre sous/hors tension l'autoradio peut aussi mettre sous/hors tension le PnP JVC.

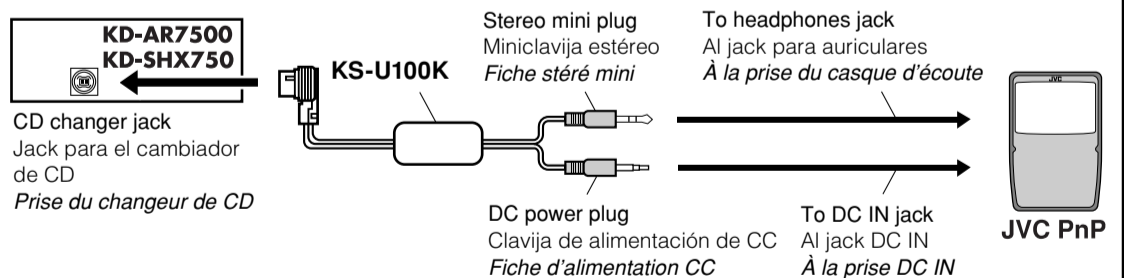

External component / Componente exterior / Appareil extérieur

- Set "Ext Input" to "Ext Input" (see page 34 of the INSTRUCTIONS). / Ajuste "Ext Input" a "Ext Input" (consulte la página 34 del MANUAL DE INSTRUCCIONES). / Réglez "Ext Input" sur "Ext Input" (voir la page 34 du MANUEL D'INSTRUCTIONS).

